



---

---

## High Speed Characterization Report

ERCD\_020\_XX\_TTR\_TED\_1\_D



**Mated with:**  
**ERF8-020-05.0-S-DV-L**



**Description:**

**0.8mm Edge Rate High Speed Coax Cable Assembly**

Series: (0.80 mm) .0315" ERCD

Description: 0.8mm Edge Rate High Speed Coax Cable Assembly

## Table of Contents

Cable Assembly Overview .....	1
Cable Assembly Speed Rating.....	2
Eye Pattern Summary .....	3
Frequency Domain Data Summary .....	7
Bandwidth Chart – Single-Ended & Differential Insertion Loss .....	8
Time Domain Data Summary .....	10
Characterization Details .....	13
Differential and Single-Ended Data.....	13
Cable assembly Signal to Ground Ratio .....	13
Eye Diagram Data .....	16
Frequency Domain Data.....	16
Time Domain Data.....	16
Appendix A – Eye Diagrams .....	18
Appendix B – Frequency Domain Response Graphs.....	26
Single Ended Application – Insertion Loss.....	26
Single Ended Application – Return Loss.....	27
Single Ended Application – NEXT Configurations .....	28
Single Ended Application – FEXT Configurations.....	30
Differential Application – Insertion Loss .....	32
Differential Application – Return Loss.....	33
Differential Application – NEXT Configurations .....	34
Differential Application – FEXT Configurations.....	36
Differential Application – Differential to Common Mode Conversion.....	38
Appendix C – Time Domain Response Graphs.....	39
Single Ended Application – Input Pulse .....	39
Single Ended Application – Cable Assembly Impedance .....	39
Single Ended Application – Cable assembly Impedance.....	40
Single Ended Application – Propagation Delay .....	42
Differential Application – Input Pulse .....	44
Differential Application – Cable Assembly Impedance.....	44
Differential Application – Cable assembly Impedance.....	45
Differential Application – Propagation Delay.....	47
Appendix D – Product and Test System Descriptions .....	49
Product Description .....	49
Test System Description.....	49
PCB Fixtures .....	50
Appendix E – Test and Measurement Setup.....	52
N5230C Measurement Setup .....	52
Test Instruments.....	52

**Series:** (0.80 mm) .0315" ERCD

**Description:** 0.8mm Edge Rate High Speed Coax Cable Assembly

Test Cables & Adapters .....	52
DSA8200 Measurement Setup .....	53
Test Instruments .....	53
Test Cables & Adapters .....	53
Appendix F - Frequency and Time Domain Measurements .....	54
Eye Diagram Procedures.....	54
Eye Mask .....	55
Rise Time .....	55
Frequency (S-Parameter) Domain Procedures .....	56
Time Domain Procedures .....	58
Impedance (TDR).....	58
Propagation Delay (TDT) .....	58
Appendix G – Glossary of Terms .....	59

**Series:** (0.80 mm) .0315" ERCD

**Description:** 0.8mm Edge Rate High Speed Coax Cable Assembly

### Cable Assembly Overview

The 0.80 mm (.0315") ERCD Edge Rate Coax Cable Assembly is a double row structure with up to 60 contacts per row. The data in this report is applicable to 9.80 and 39.37 inch cable assembly.

The test sample consists of two micro-coaxial ribbon cables that contain 20 lines each. At each end of the cable is a connector that is terminated to a small transition PCB. Each connector is soldered to its respective PCB. The connector terminals are on 0.8 mm centers. The ERCD-020-XX-TTR-TED-1-D assembly is wired to facilitate a Pin 1 to Pin 1 mapping between the cable ends.

The ERCD assemblies were tested by mating to ERF8-020-05.0-S-DV-L at both ends. One sample of each length assembly was tested. The actual part number that was tested is shown in Table 1, which also identifies End 1 and End 2 of the assembly; a relative sample picture is shown in Figure 1. Two lines, a Long Path and a Short Path, of each assembly type were tested.

Length	Part Number	End 1	End 2
9.80 inches	ERCD-020-09.80-TTR-TED-1-D	ERM8	ERM8
39.37 inches	ERCD-020-39.37-TTR-TED-1-D	ERM8	ERM8

**Table 1: Sample Description**

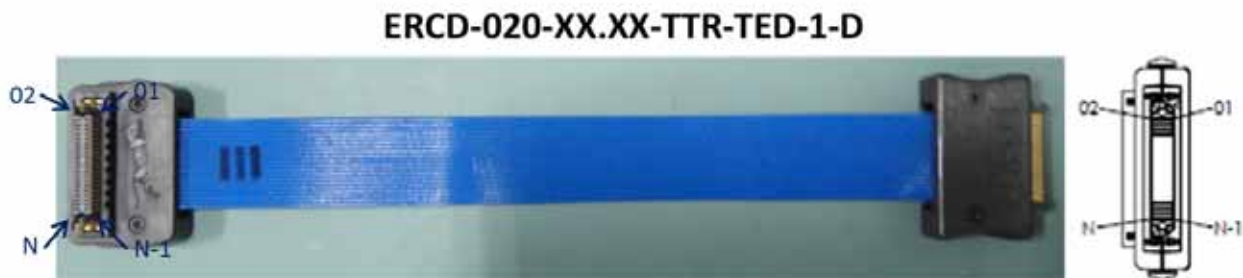

**Figure 1: Test Sample**

**Series:** (0.80 mm) .0315" ERCD

**Description:** 0.8mm Edge Rate High Speed Coax Cable Assembly

## Cable Assembly Speed Rating

The cable assembly Speed Rating is based on the  $-7$  dB insertion loss point of the mated cable assembly. The  $-7$  dB point can be used to estimate usable system bandwidth in a typical two-level signaling environment.

To calculate the Speed Rating, the measured  $-7$  dB point is rounded up to the nearest half-GHz level. The up-rounding corrects for any loss from the test board traces. The resulting loss value is then doubled to determine the approximate maximum data rate in Gigabits per second (Gbps). The following table summarizes the Cable Assembly Speed Ratings for the ERCD cable assemblies tested.

Assembly			-7 dB Frequency	Speed Rating
ERCD-020-09.80-TTR-TED-1-D	Single Ended	Long Row	3.5 GHz	7 Gbps
		Short Row	6.0 GHz	12 Gbps
	Differential	Long Row	8.5 GHz	17 Gbps
		Short Row	11.0 GHz	22 Gbps
ERCD-020-39.37-TTR-TED-1-D	Single Ended	Long Row	2.5 GHz	5 Gbps
		Short Row	2.5 GHz	5 Gbps
	Differential	Long Row	5.0 GHz	10 Gbps
		Short Row	4.5 GHz	9 Gbps

**Table 2: Cable Assembly Speed Rating**

The Samtec Speed Rating is best considered a figure of merit for comparing relative performance between cable assemblies. The Speed Rating becomes less meaningful in systems using multi-level signaling or where crosstalk or impedance mismatch are more critical parameters. Modern high-speed digital transceivers can accommodate roughly 9 dB of loss and still operate reliably. The  $-7$  dB rating is a conservative number that allocates 2 dB of system budget for other channel components such as short PCB traces and IC packaging effects.

Series: (0.80 mm) .0315" ERCD

Description: 0.8mm Edge Rate High Speed Coax Cable Assembly

### Eye Pattern Summary

ERCD-020-09.80-TTR-TED-1-D

#### Single-Ended

Long Row Output Eye : 7Gbps

Short Row Output Eye : 12Gbps

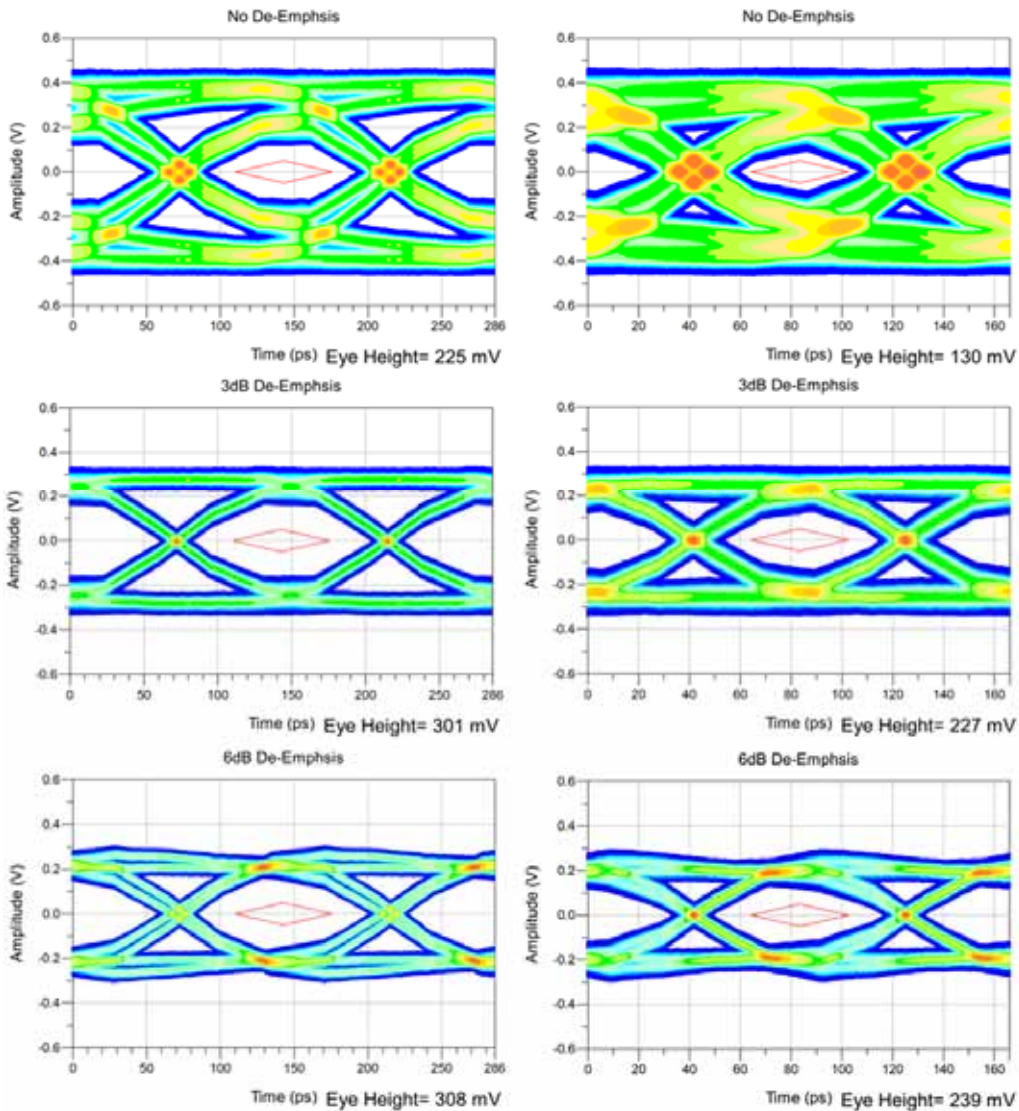

**Series:** (0.80 mm) .0315" ERCD

**Description:** 0.8mm Edge Rate High Speed Coax Cable Assembly

ERCD-020-09.80-TTR-TED-1-D

## Differential

Long Row Output Eye : 17Gbps

Short Row Output Eye : 22Gbps

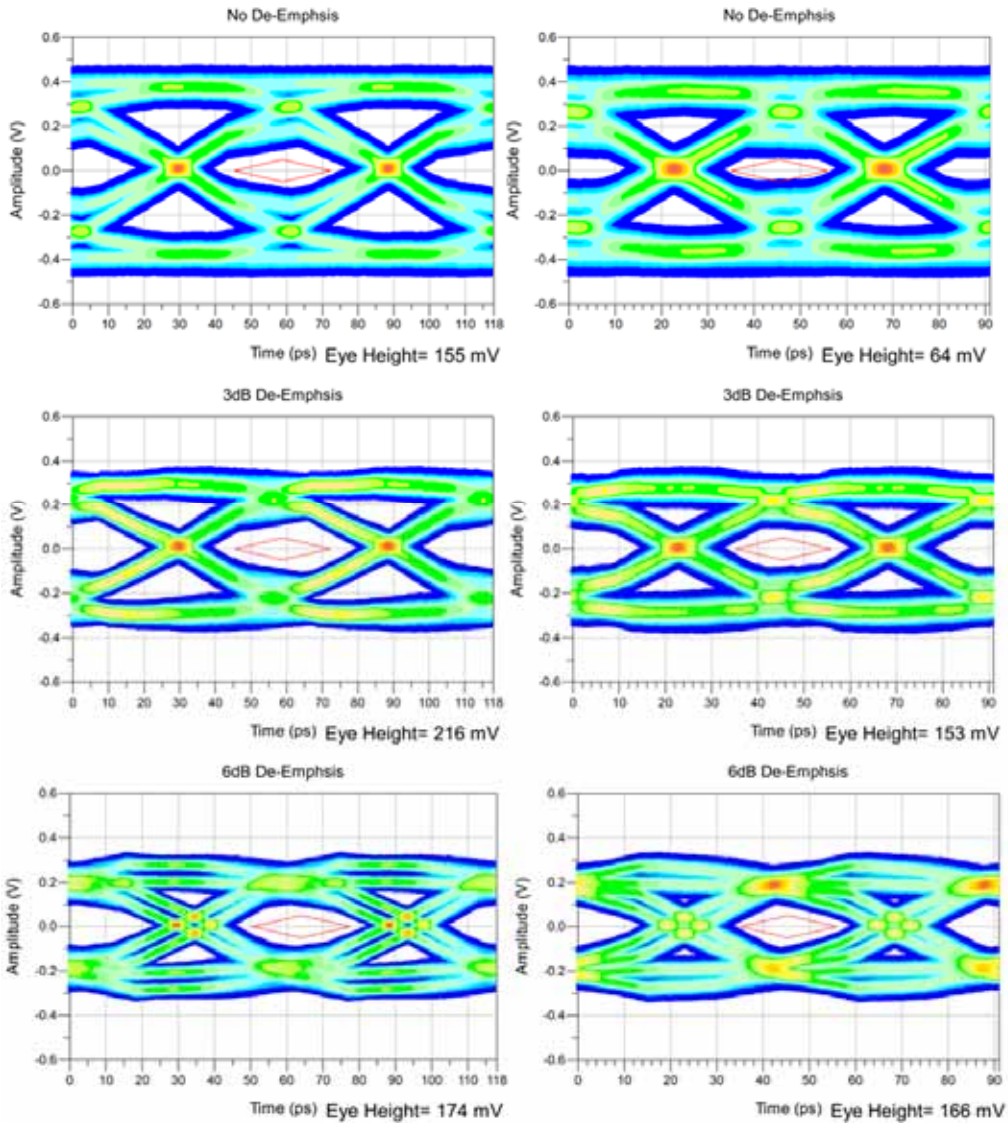

**Series:** (0.80 mm) .0315" ERCD

**Description:** 0.8mm Edge Rate High Speed Coax Cable Assembly

ERCD-020-39.37-TTR-TED-1-D

## Single-Ended

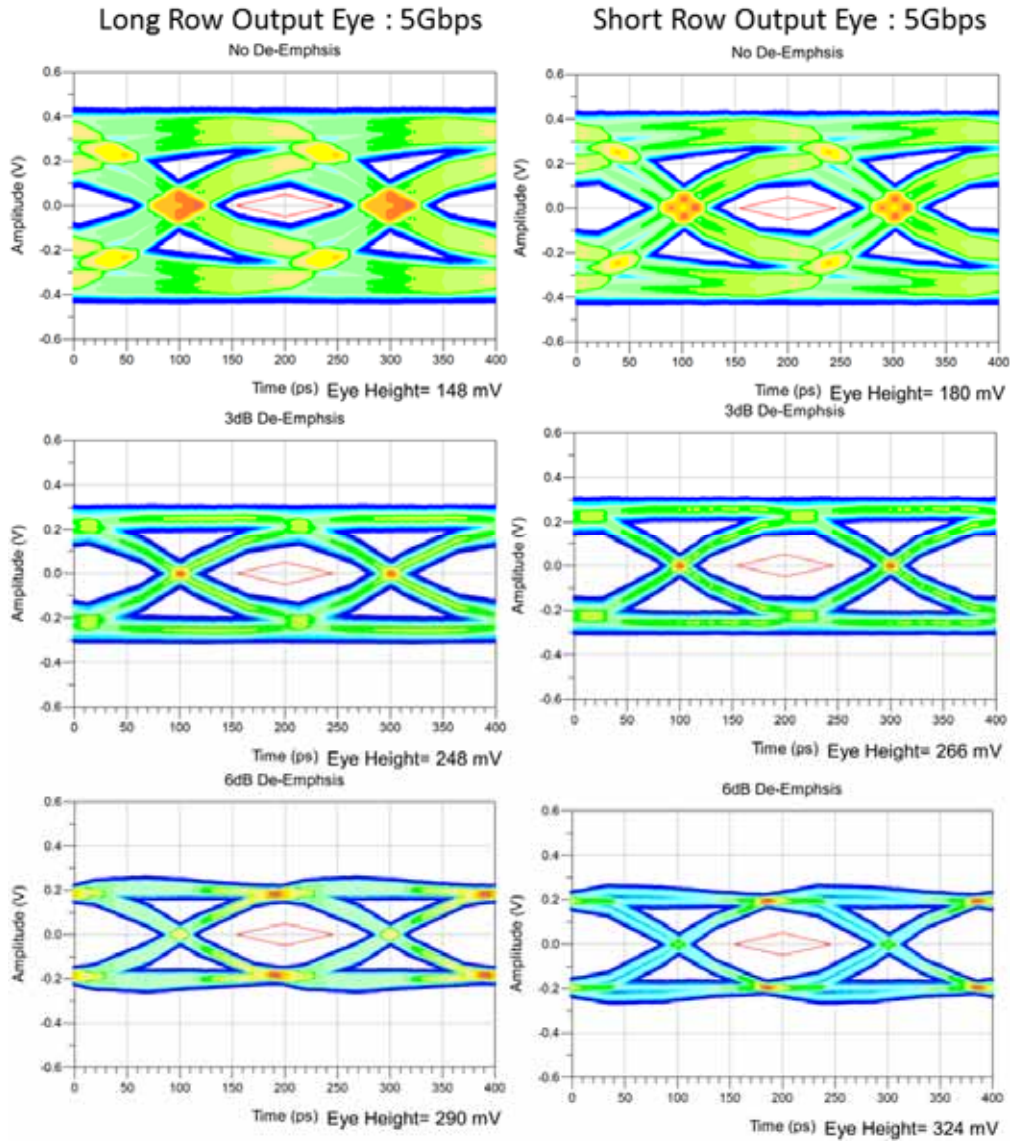

**Series:** (0.80 mm) .0315" ERCD

**Description:** 0.8mm Edge Rate High Speed Coax Cable Assembly

ERCD-020-39.37-TTR-TED-1-D

## Differential

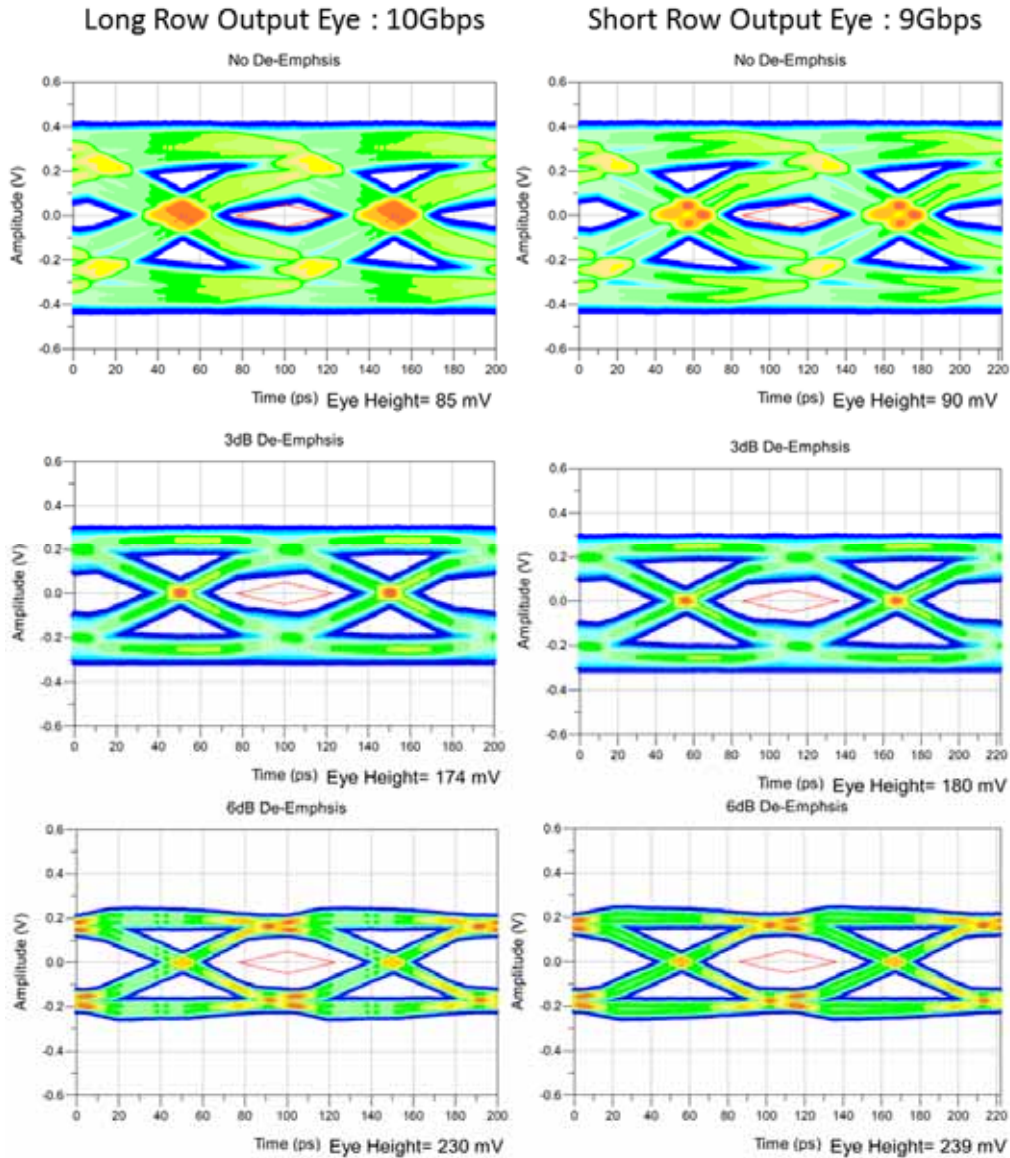



Series: (0.80 mm) .0315" ERCD

Description: 0.8mm Edge Rate High Speed Coax Cable Assembly

Frequency Domain Data Summary

Table 3 – Cable Assembly System Performance					
Test Parameter	Configuration	Driver	Receiver	0.25m	1m
Insertion Loss	S.E.	TTR1_ERM8_2	TED2_ERM8_2	7dB@ 3.4 GHz	7dB@ 2.1 GHz
		TTR1_ERM8_21	TED2_ERM8_21	7dB@ 5.8 GHz	7dB@ 2.4 GHz
	DIFF.	TTR1_ERM8_2,4	TED2_ERM8_2,4	7dB@ 8.4 GHz	7dB@ 4.6 GHz
		TTR1_ERM8_21,23	TED2_ERM8_21,23	7dB@ 10.8 GHz	7dB@ 4.3 GHz
Return Loss	S.E.	TTR1_ERM8_2	TTR1_ERM8_2	>10dB to 1.2 GHz	>10dB to 2.5 GHz
		TTR1_ERM8_21	TTR1_ERM8_21	>10dB to 4.0 GHz	>10dB to 4.8 GHz
	DIFF.	TTR1_ERM8_2,4	TTR1_ERM8_2,4	>10dB to 1.7 GHz	>10dB to 1.8 GHz
		TTR1_ERM8_21,23	TTR1_ERM8_21,23	>10dB to 1.7 GHz	>10dB to 1.9 GHz
Near-End Crosstalk	S.E.	TTR1_ERM8_2	TTR1_ERM8_1	<-20dB to 7.5 GHz	<-20dB to 7.5 GHz
		TTR1_ERM8_2	TTR1_ERM8_4	<-20dB to 0.3 GHz	<-20dB to 0.2 GHz
		TTR1_ERM8_21	TTR1_ERM8_19	<-20dB to 0.3 GHz	<-20dB to 0.2 GHz
		TTR1_ERM8_21	TTR1_ERM8_22	<-20dB to 19 GHz	<-20dB to 19 GHz
	DIFF.	TTR1_ERM8_2,4	TTR1_ERM8_1,3	<-20dB to 20 GHz	<-20dB to 20 GHz
		TTR1_ERM8_2,4	TTR1_ERM8_6,8	<-20dB to 1.6 GHz	<-20dB to 3.2 GHz
		TTR1_ERM8_21,23	TTR1_ERM8_17,19	<-20dB to 1.3 GHz	<-20dB to 2.5 GHz
		TTR1_ERM8_21,23	TTR1_ERM8_22,24	<-20dB to 20 GHz	<-20dB to 20 GHz
Far-End Crosstalk	S.E.	TTR1_ERM8_2	TED2_ERM8_1	<-20dB to 20 GHz	<-20dB to 20 GHz
		TTR1_ERM8_2	TED2_ERM8_4	<-20dB to 0.2 GHz	<-20dB to 0.3 GHz
		TTR1_ERM8_21	TED2_ERM8_19	<-20dB to 0.5 GHz	<-20dB to 0.5 GHz
		TTR1_ERM8_21	TED2_ERM8_22	<-20dB to 20 GHz	<-20dB to 20 GHz
	DIFF.	TTR1_ERM8_2,4	TED2_ERM8_1,3	<-20dB to 20 GHz	<-20dB to 20 GHz
		TTR1_ERM8_2,4	TED2_ERM8_6,8	<-20dB to 7.1 GHz	<-20dB to 20 GHz
		TTR1_ERM8_21,23	TED2_ERM8_17,19	<-20dB to 11.1 GHz	<-20dB to 20 GHz
		TTR1_ERM8_21,23	TED2_ERM8_22,24	<-20dB to 20 GHz	<-20dB to 20 GHz

**Series:** (0.80 mm) .0315" ERCD

**Description:** 0.8mm Edge Rate High Speed Coax Cable Assembly

## Bandwidth Chart – Single-Ended & Differential Insertion Loss

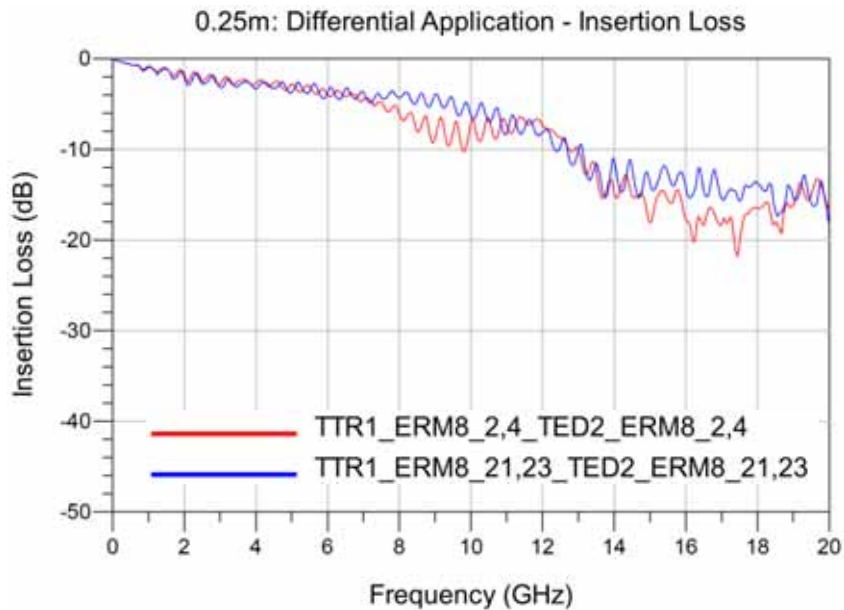
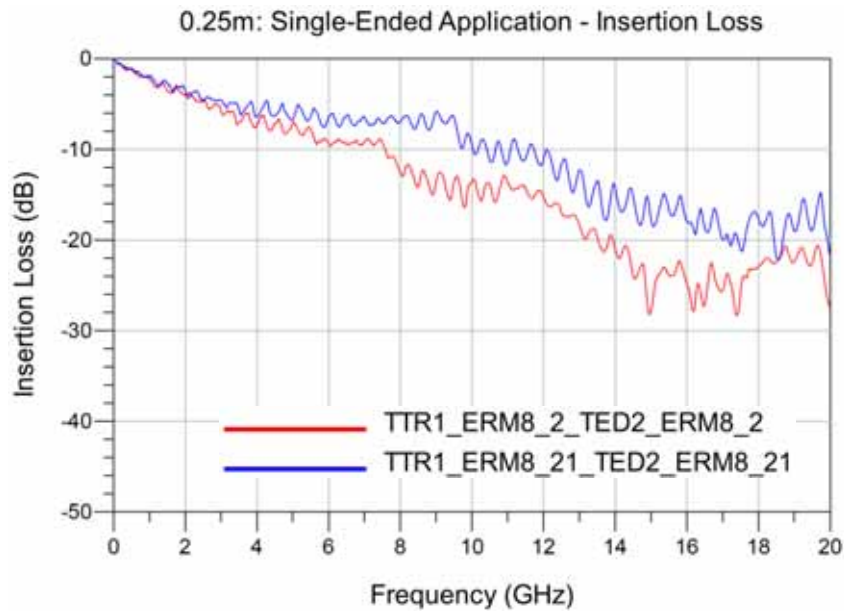

Series: (0.80 mm) .0315" ERCD

Description: 0.8mm Edge Rate High Speed Coax Cable Assembly

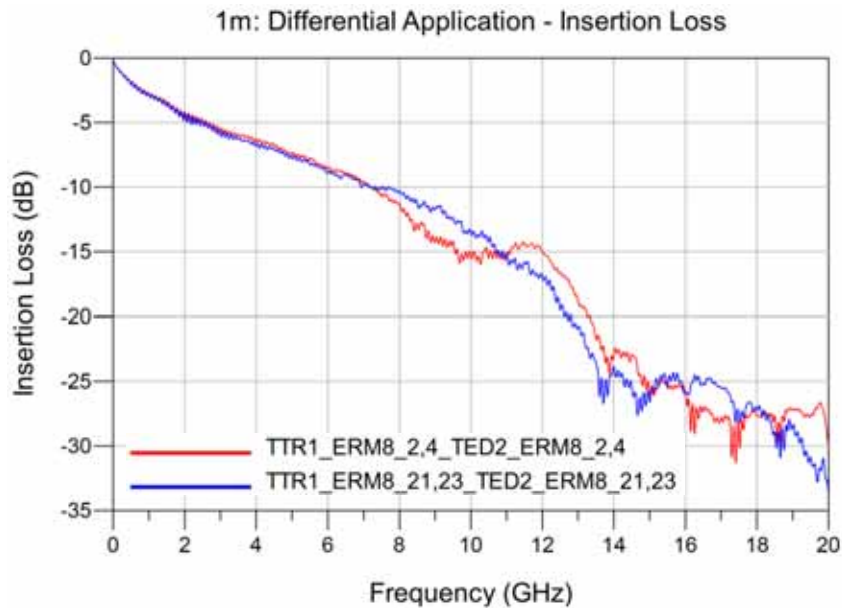
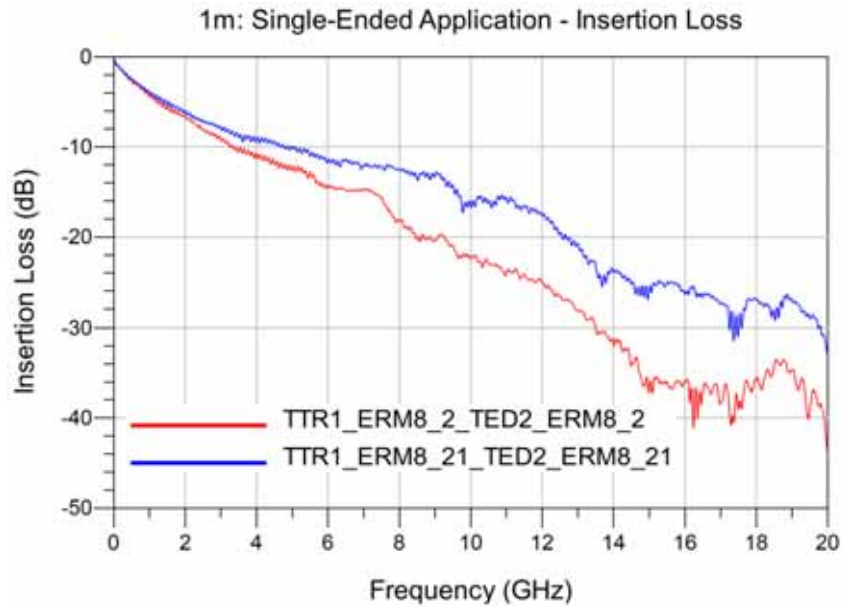

**Series:** (0.80 mm) .0315" ERCD

**Description:** 0.8mm Edge Rate High Speed Coax Cable Assembly

## Time Domain Data Summary

### 0.25m : Single Ended Application \_ Impedance

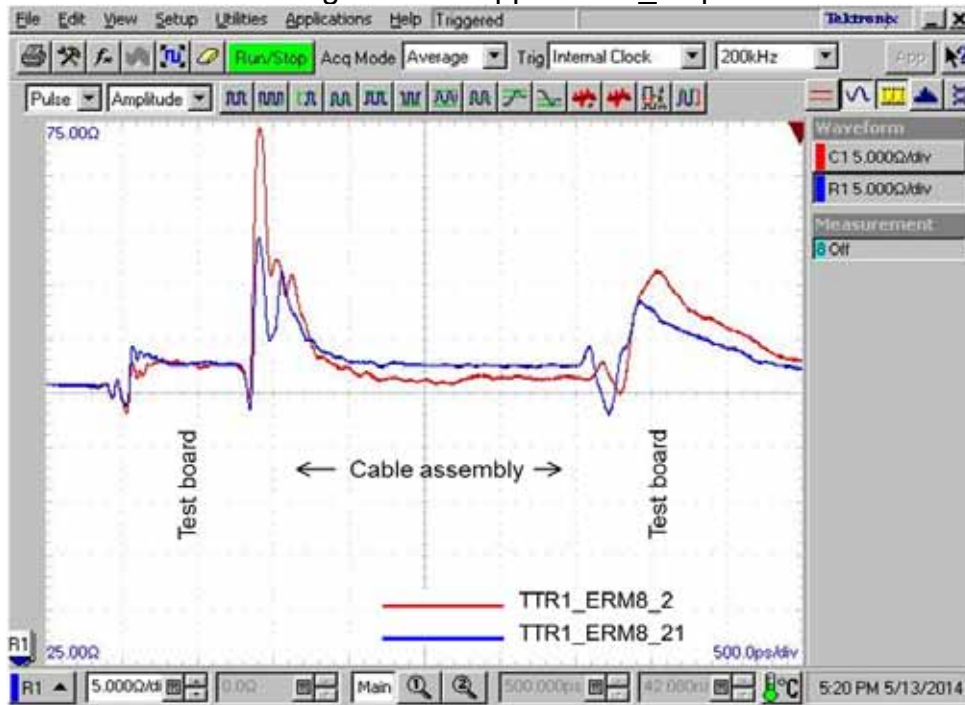

### 0.25m : Differential Application \_ Impedance

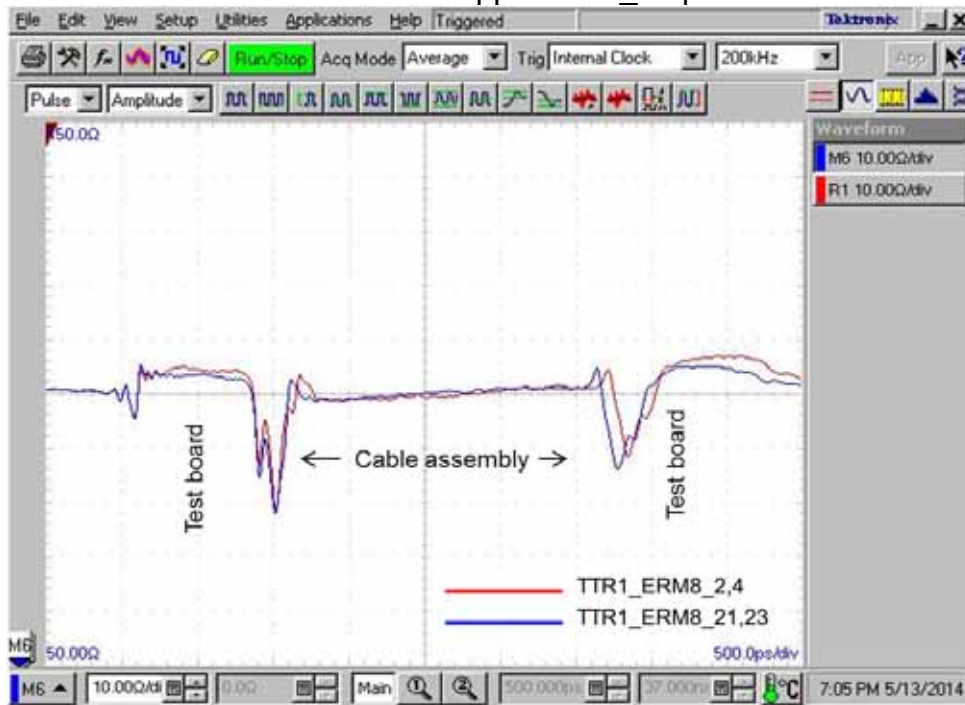

**Series:** (0.80 mm) .0315" ERCD

**Description:** 0.8mm Edge Rate High Speed Coax Cable Assembly

## 1m : Single Ended Application \_ Impedance

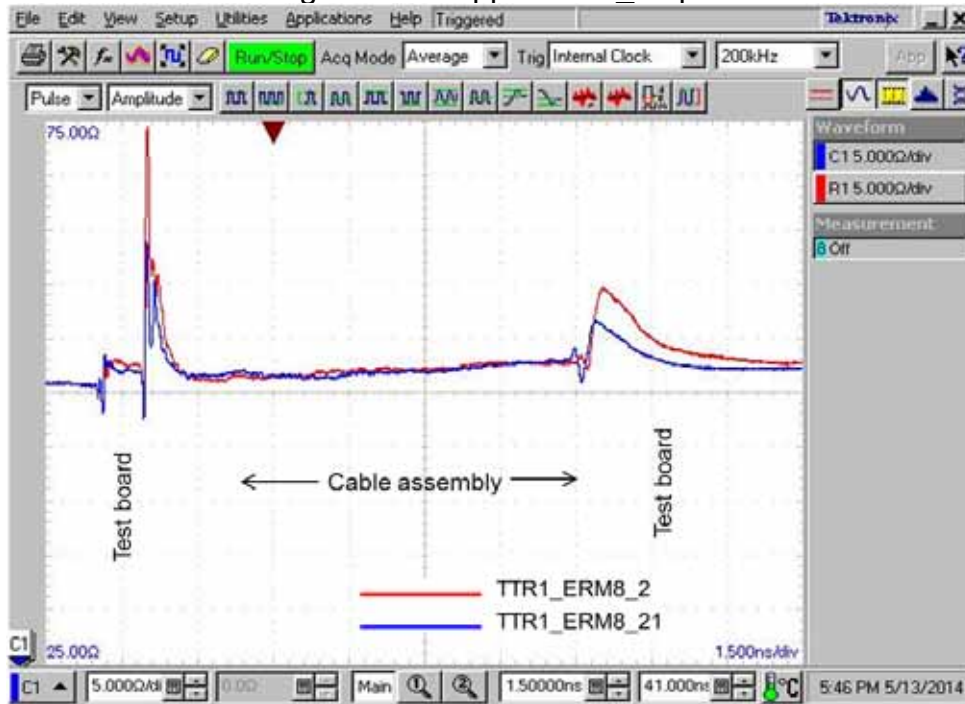

## 1m : Differential Application \_ Impedance

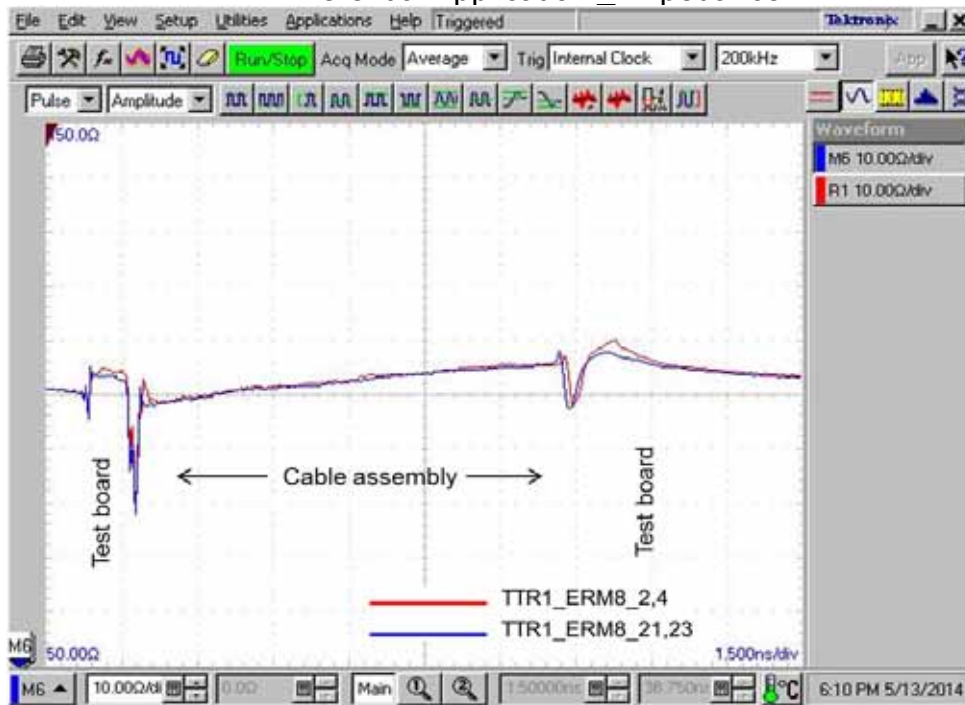



Series: (0.80 mm) .0315" ERCD

Description: 0.8mm Edge Rate High Speed Coax Cable Assembly

Table 4 - Propagation Delay (Cable Assembly)

Cable length	Driver/ Receiver	Driver/ Receiver	Driver/ Receiver	Driver/ Receiver
	TTR1_ERM8_2/ TED2_ERM8_2	TTR1_ERM8_21/ TED2_ERM8_21	TTR1_ERM8_2,4/ TED2_ERM8_2,4	TTR1_ERM8_21,23/ TED2_ERM8_21,23
0.25m	1.32ns	1.26ns	1.22ns	1.25ns
1m	4.53ns	4.46ns	4.47ns	4.42ns

**Series:** (0.80 mm) .0315" ERCD

**Description:** 0.8mm Edge Rate High Speed Coax Cable Assembly

### Characterization Details

This report presents data that characterizes the signal integrity response of a cable assembly in a controlled printed circuit board (PCB) environment. All efforts are made to reveal typical best-case responses inherent to the system under test (SUT).

In this report, the SUT includes the mating connectors, cable assembly, and footprint effects on a typical multi-layer PCB. PCB effects (trace loss) are de-embedded from test data. Board related effects, such as pad-to-ground capacitance, are included in the data presented in this report.

Additionally, intermediate test signal connections can mask the cable assembly's true performance. Such connection effects are minimized by using high performance test cables and adapters. Where appropriate, calibration and de-embedding routines are also used to reduce residual effects.

### Differential and Single-Ended Data

Most Samtec cable assemblies can be used successfully in both differential and single-ended applications. However, electrical performance will differ depending on the signal drive type. In this report, data is presented for "S" single-ended and "SS" differential drive configurations

### Cable assembly Signal to Ground Ratio

Samtec cable assemblies are most often designed for generic applications and can be implemented using various signal and ground pin assignments. In high speed systems, provisions must be made in the interconnect for signal return currents. Such paths are often referred to as "ground". In some cable assemblies, a ground plane or blade, or an outer shield, is used as the signal return, while in others, cable assembly pins are used as signal returns. Various combinations of signal pins, ground blades, and shields can also be utilized. Electrical performance can vary significantly depending upon the number and location of ground pins.

In general, the more pins dedicated to ground, the better electrical performance will be. But dedicating pins to ground reduces signal density of a cable assembly. Therefore, care must be taken when choosing signal/ground ratios in cost or density-sensitive applications.

**Series:** (0.80 mm) .0315" ERCD

**Description:** 0.8mm Edge Rate High Speed Coax Cable Assembly

For this cable assembly, the following array configurations are evaluated:

Single-Ended Impedance:

- Long Row (upper terminals, furthest from test fixture)
- Short Row (bottom terminals, closest to test fixture)

Single-Ended Crosstalk:

- In Row: Long Row (adjacent terminals in the long row)
- In Row: Short Row (adjacent terminals in the short row)
- Cross Row: "Xrow": (from one row of terminals to the other row)

Differential Impedance:

- Long Row (upper terminals, furthest from test fixture)
- Short Row (bottom terminals, closest to test fixture)

Differential Crosstalk:

- In Row: Long Row (adjacent terminals in the long row)
- In Row: Short Row (adjacent terminals in the short row)
- Cross Row: "Xrow": (from one row of terminals to the other row)

See Appendix D – Product and Test System Descriptions for details

Only one single-ended and one differential pair for long row and short row were driven for crosstalk measurements.

Other configurations can be evaluated upon request. Please contact [sig@samtec.com](mailto:sig@samtec.com) for more information.

In a real system environment, active signals might be located at the outer edges of the signal contacts of concern, as opposed to the ground signals utilized in laboratory testing. For example, in a single-ended system, a pin-out of "SSSS", or four adjacent single ended signals might be encountered as opposed to the "GSG" and "GSSG" configurations tested in the laboratory. Electrical characteristics in such applications could vary slightly from laboratory results. But in most applications, performance can safely be considered equivalent.

### Signal Edge Speed (Rise Time)

In pulse signaling applications, the perceived performance of the interconnect can vary significantly depending on the edge rate or rise time of the exciting signal. For this report, the fastest rise time used was 30 ps. Generally, this should demonstrate worst-case performance.

**Series:** (0.80 mm) .0315" ERCD

**Description:** 0.8mm Edge Rate High Speed Coax Cable Assembly

In many systems, the signal edge rate will be significantly slower at the cable assembly than at the driver launch point. To estimate interconnect performance at other edge rates, data is provided for several rise times between 30ps and 500ps.

Unless otherwise stated, measured rise times were at 10%-90% signal levels.

**Series:** (0.80 mm) .0315" ERCD

**Description:** 0.8mm Edge Rate High Speed Coax Cable Assembly

### Eye Diagram Data

Eye patterns are a time domain characterization of system level performance. Eye patterns are generated by sending continuous streams of data from a transmitter to a receiver, and overlaying the received signals upon one another. Over time, the received data builds to resemble an eye. Negative SI effects in the transmission path can cause the signal to distort, which over time, will cause the eye to “close”. Specifications, such as an eyemask template, can be placed on the amount of open area required in the eye to ensure a functional system.

An eyemask template is a representation of the receiver’s sensitivity and is often used as a metric of performance. While there are lot-to-lot and vendor-to-vendor variations in receiver sensitivity, some general guidelines can be developed. After reviewing several major industry standards (PCIe, Gigabit Ethernet) we find similar eyemask requirements and we will use these as the basis for a generic template in this report. For this report we will assume a receiver amplitude sensitivity of 50 mVpp and a jitter margin of 0.5 UI. This results in a diamond shape eyemask template that is 50 mV high and 0.5 UI wide.

Please contact our Signal Integrity Group at [sig@samtec.com](mailto:sig@samtec.com) for more information.

### Frequency Domain Data

Frequency Domain parameters are helpful in evaluating the cable assembly system’s signal loss and crosstalk characteristics across a range of sinusoidal frequencies. In this report, parameters presented in the Frequency Domain are Insertion Loss, Return Loss, Near-End and Far-End Crosstalk, and Mode Conversion. Other parameters or formats, such as VSWR or S-Parameters, may be available upon request. Please contact our Signal Integrity Group at [sig@samtec.com](mailto:sig@samtec.com) for more information.

Frequency performance characteristics for the SUT are generated directly from network analyzer measurements.

### Time Domain Data

Time Domain parameters indicate Impedance mismatch versus length, signal propagation time, and crosstalk in a pulsed signal environment.

Impedance mismatch versus length is measured by DSA8200 Digital Serial Analyzer. Board related effects, such as pad-to-ground capacitance and trace loss, are included in the data presented in this report. The impedance data is provided in [Appendix E](#) of this report.

The measured S-Parameters from the network analyzer are post-processed using Agilent Advanced Design System to obtain the time domain response for signal propaga-

**Series:** (0.80 mm) .0315" ERCD

**Description:** 0.8mm Edge Rate High Speed Coax Cable Assembly

tion time and crosstalk. The Time Domain procedure is provided in [Appendix E](#) of this report. Parameters or formats not included in this report may be available upon request. Please contact our Signal Integrity Group at [sig@samtec.com](mailto:sig@samtec.com) for more information.

In this report, propagation delay is defined as the signal propagation time through the cable assembly, mating connectors, and connector footprint. It includes 10 mils of PCB trace on each end of the connector. Delay is measured at 30 picoseconds signal rise-time. Delay is calculated as the difference in time measured between the 50% amplitude levels of the input and output pulses.

Data for other configurations may be available. Please contact our Signal Integrity Group at [sig@samtec.com](mailto:sig@samtec.com) for further information.

Additional information concerning test conditions and procedures is located in the appendices of this report. Further information may be obtained by contacting our Signal Integrity Group at [sig@samtec.com](mailto:sig@samtec.com).

Series: (0.80 mm) .0315" ERCD

Description: 0.8mm Edge Rate High Speed Coax Cable Assembly

### Appendix A – Eye Diagrams

ERCD-020-09.80-TTR-TED-1-D

Single Ended

### 7Gbps : Long Row

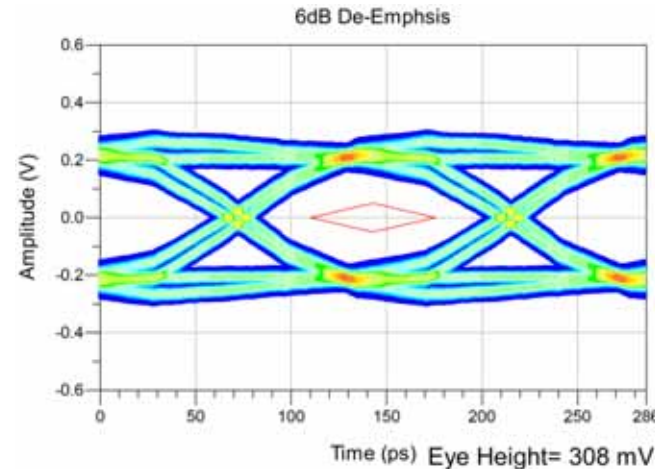
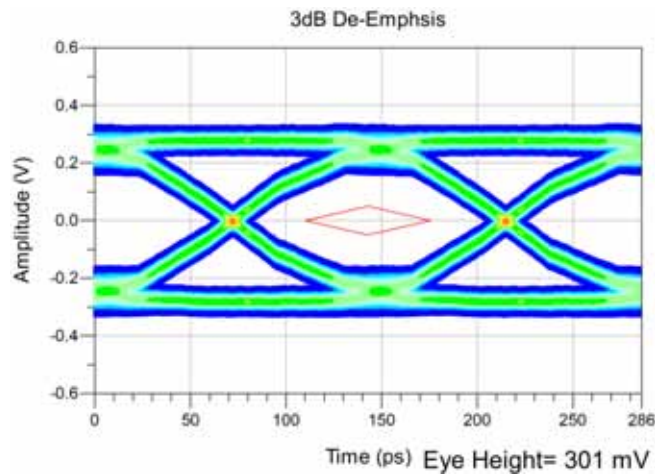
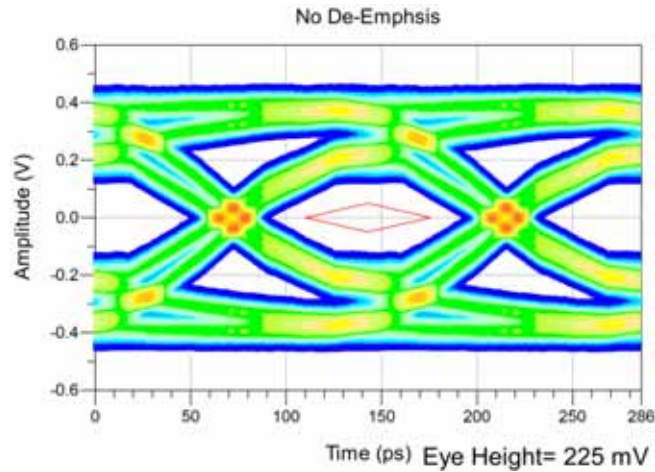

Series: (0.80 mm) .0315" ERCD

Description: 0.8mm Edge Rate High Speed Coax Cable Assembly

Single Ended

## 12Gbps : Short Row

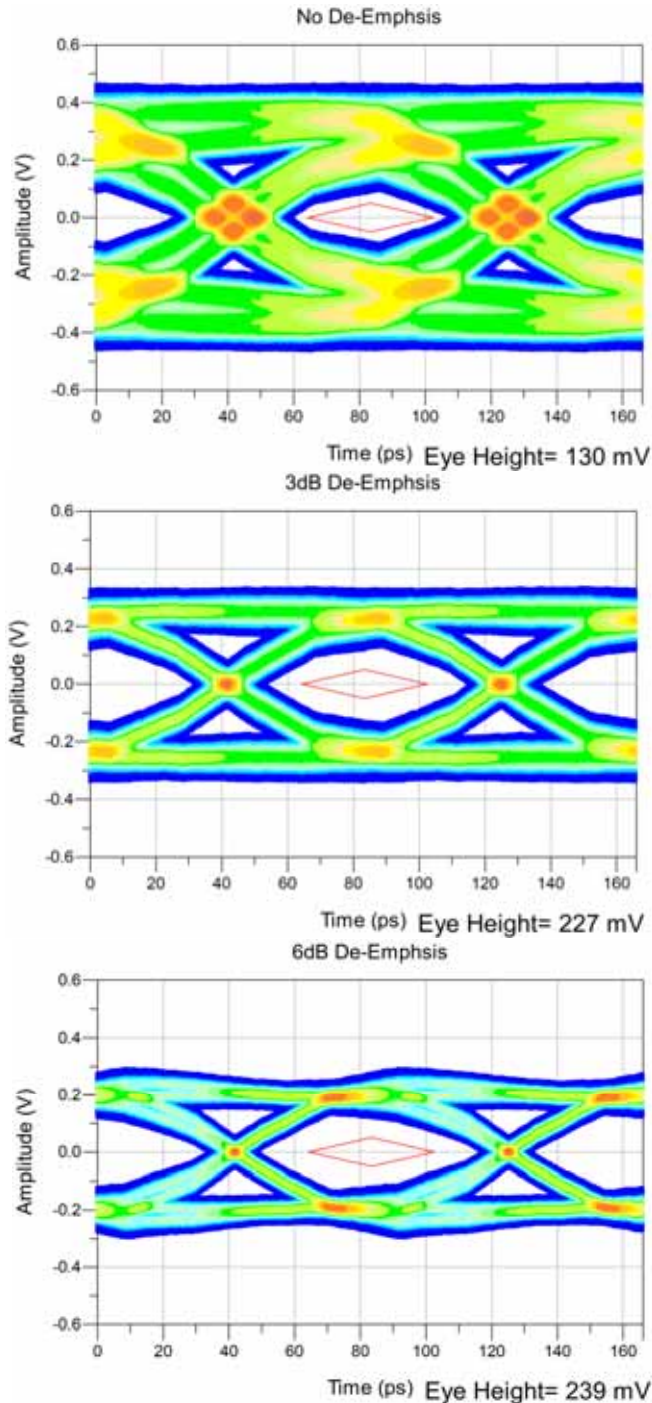

Series: (0.80 mm) .0315" ERCD

Description: 0.8mm Edge Rate High Speed Coax Cable Assembly

Differential

## 17Gbps : Long Row

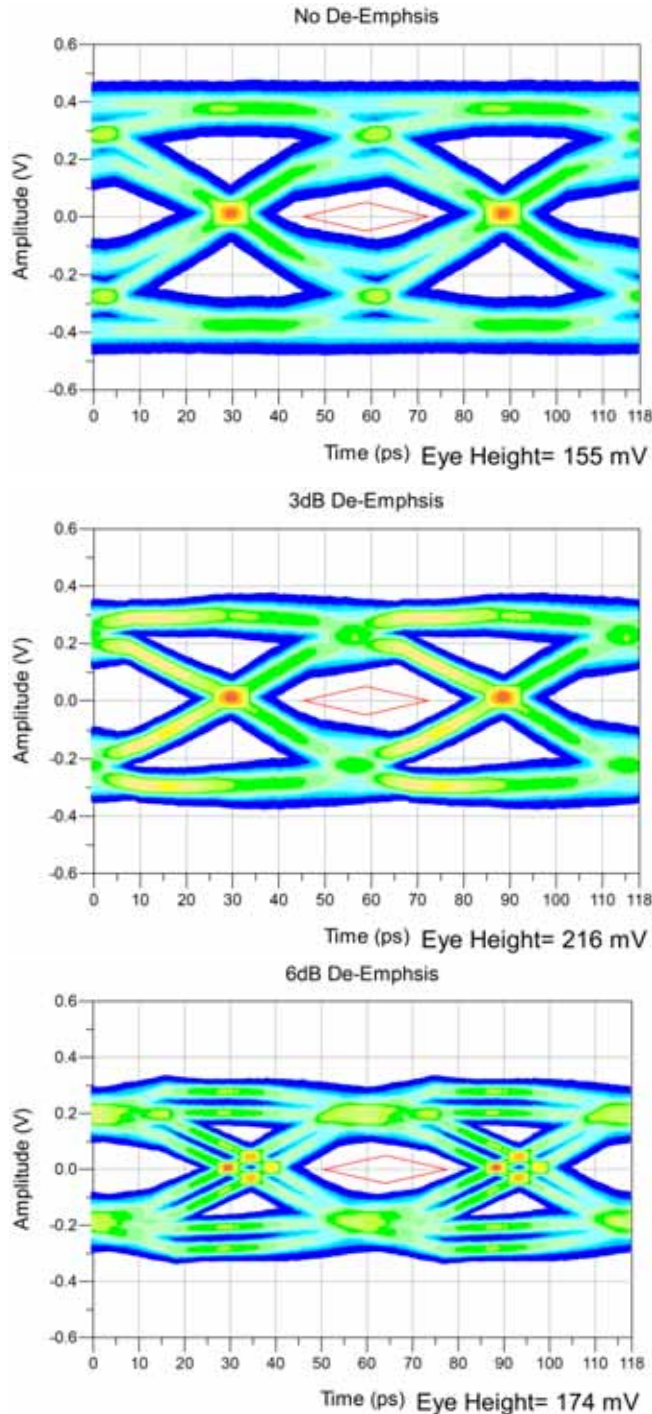

**Series:** (0.80 mm) .0315" ERCD

**Description:** 0.8mm Edge Rate High Speed Coax Cable Assembly

Differential

## 22Gbps : Short Row

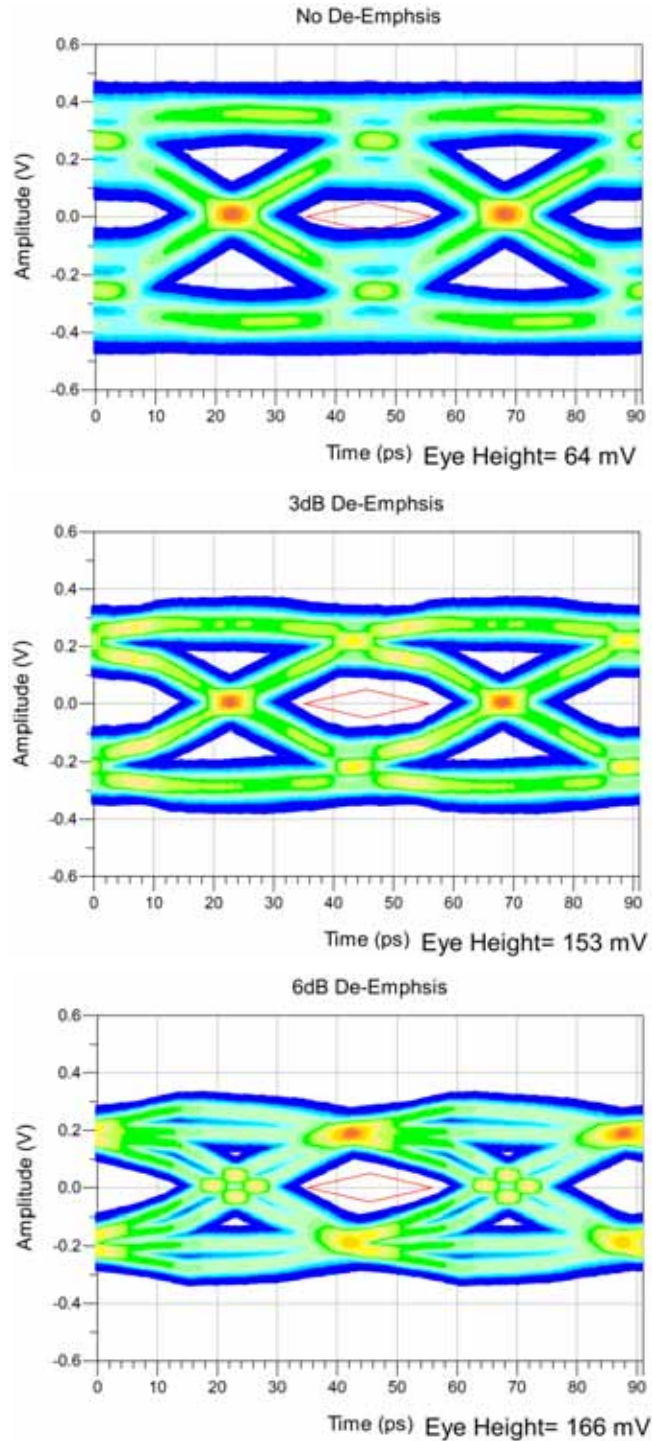

Series: (0.80 mm) .0315" ERCD

Description: 0.8mm Edge Rate High Speed Coax Cable Assembly

ERCD-020-39.37-TTR-TED-1-D

Single Ended

5Gbps : Long Row

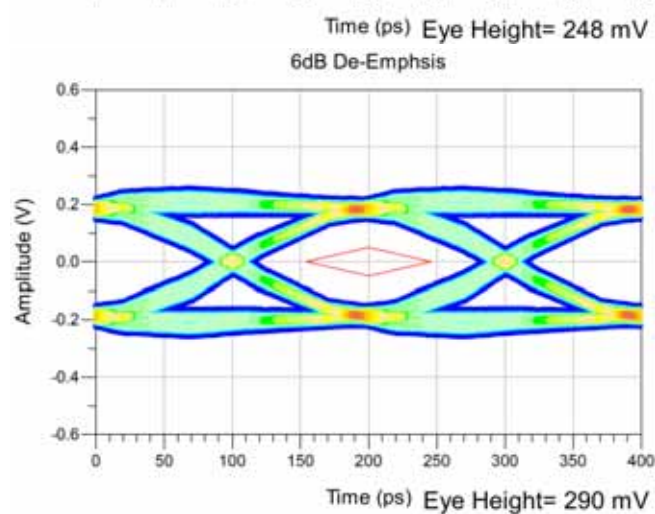
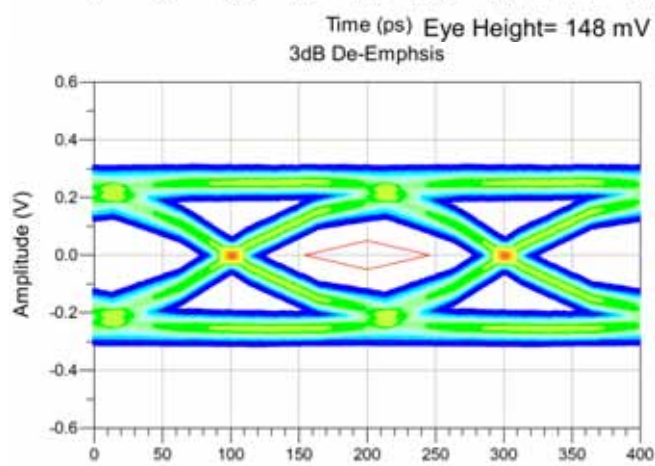
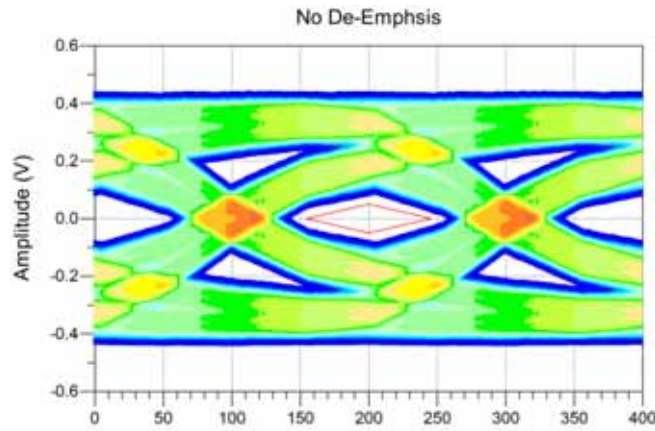

Series: (0.80 mm) .0315" ERCD

Description: 0.8mm Edge Rate High Speed Coax Cable Assembly

Single Ended

### 5Gbps : Short Row

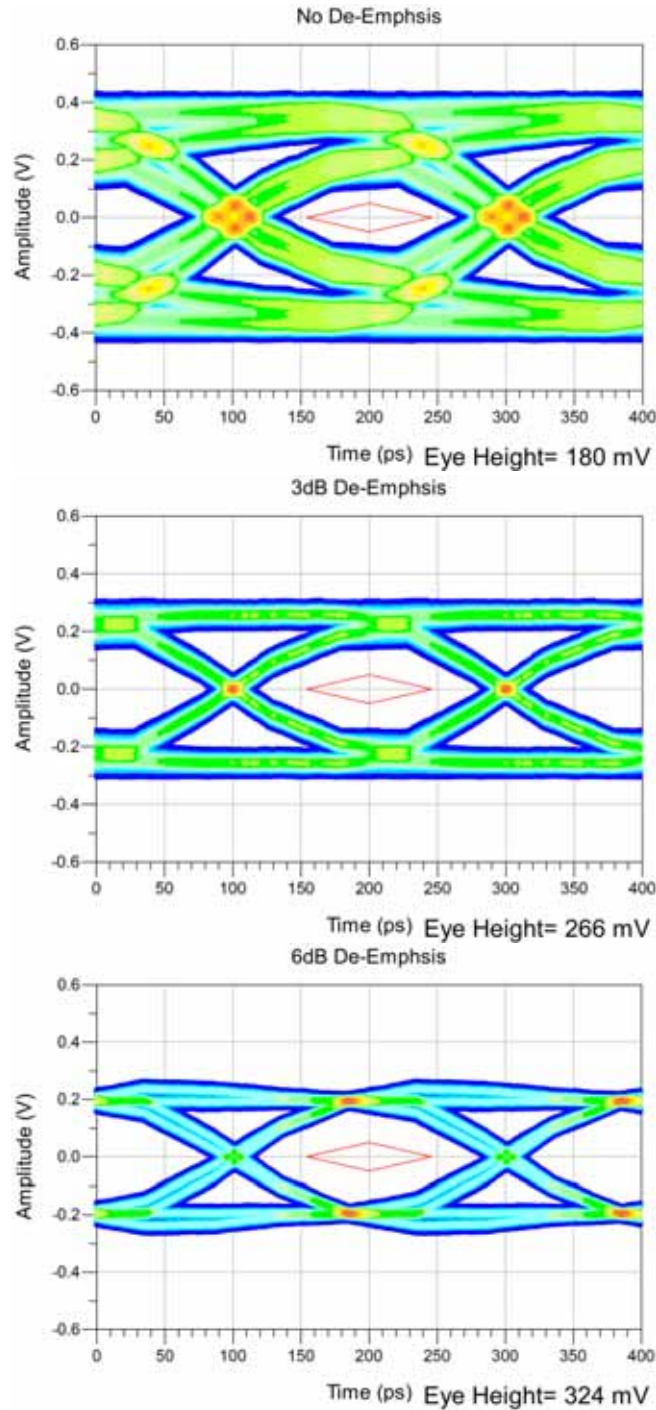

Series: (0.80 mm) .0315" ERCD

Description: 0.8mm Edge Rate High Speed Coax Cable Assembly

Differential

### 10Gbps : Long Row

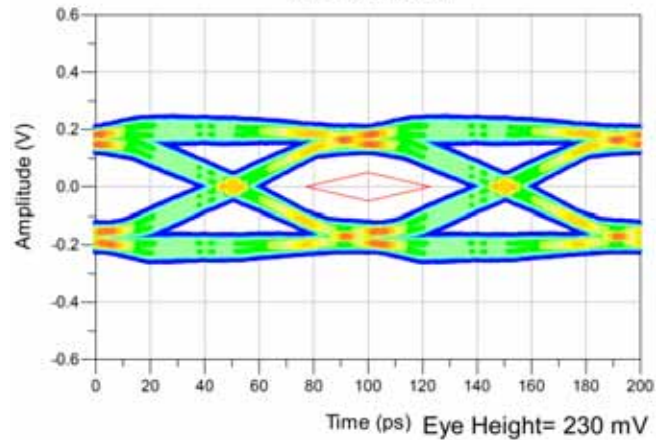
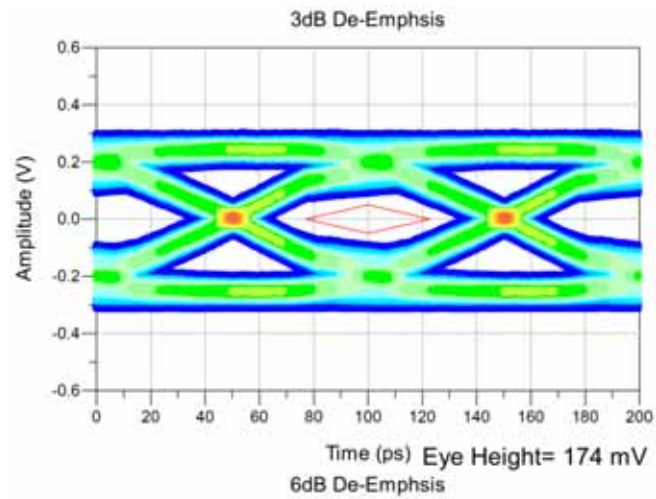
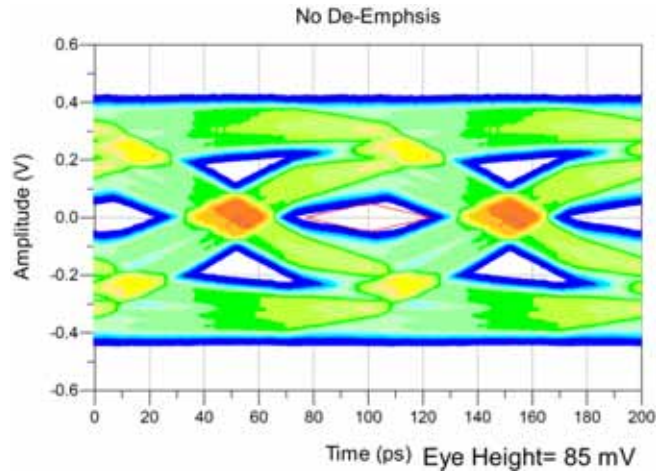

Series: (0.80 mm) .0315" ERCD

Description: 0.8mm Edge Rate High Speed Coax Cable Assembly

Differential

## 9Gbps : Short Row

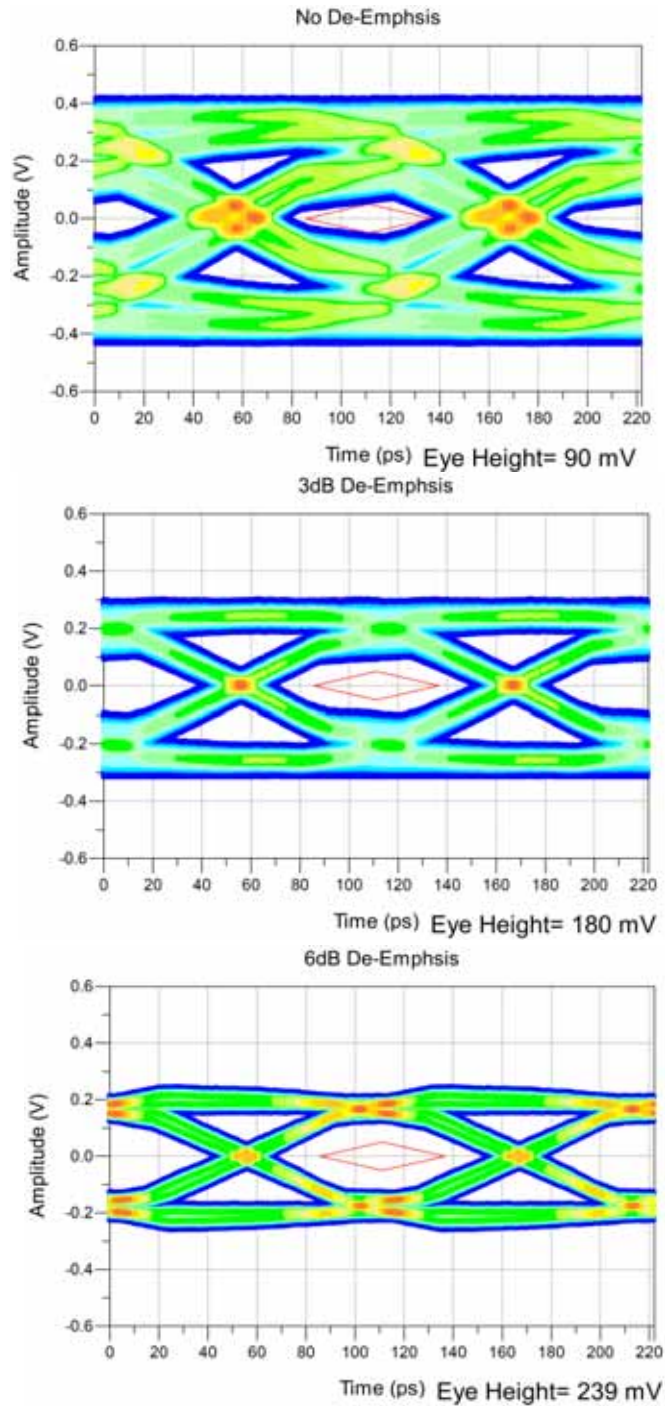

Series: (0.80 mm) .0315" ERCD

Description: 0.8mm Edge Rate High Speed Coax Cable Assembly

### Appendix B – Frequency Domain Response Graphs

#### Single Ended Application – Insertion Loss

0.25m: Single-Ended Application - Insertion Loss

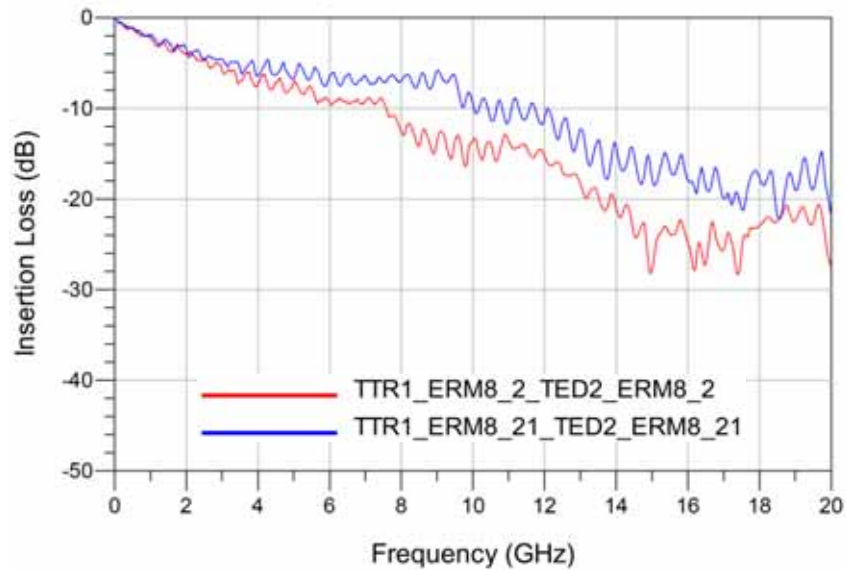

1m: Single-Ended Application - Insertion Loss

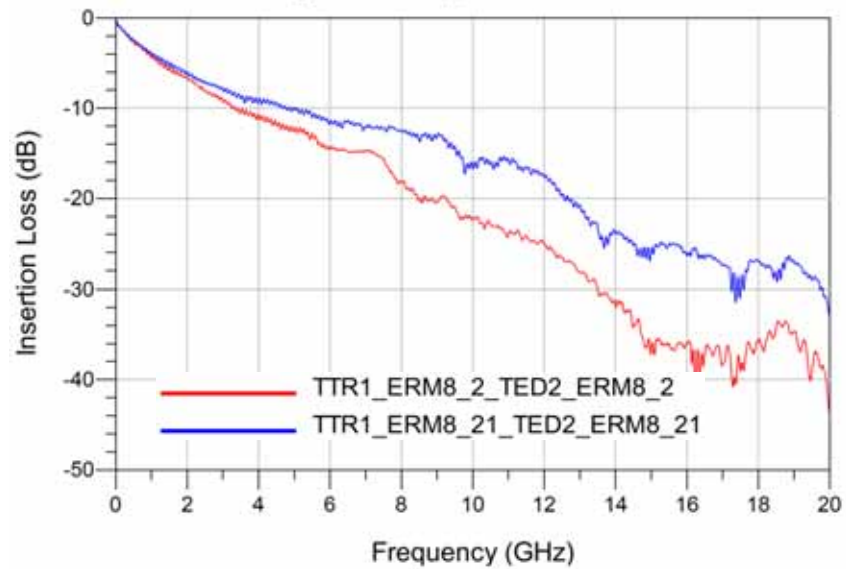

Series: (0.80 mm) .0315" ERCD

Description: 0.8mm Edge Rate High Speed Coax Cable Assembly

### Single Ended Application – Return Loss

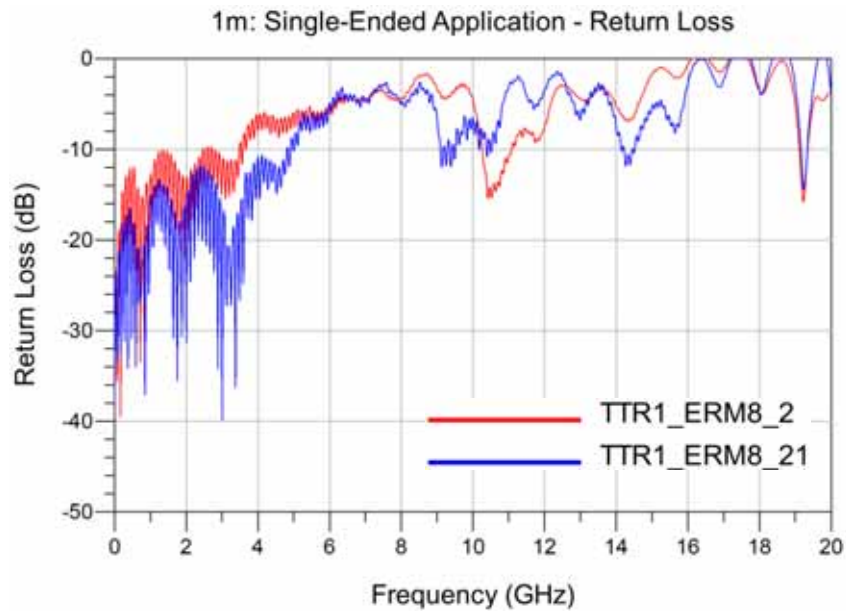
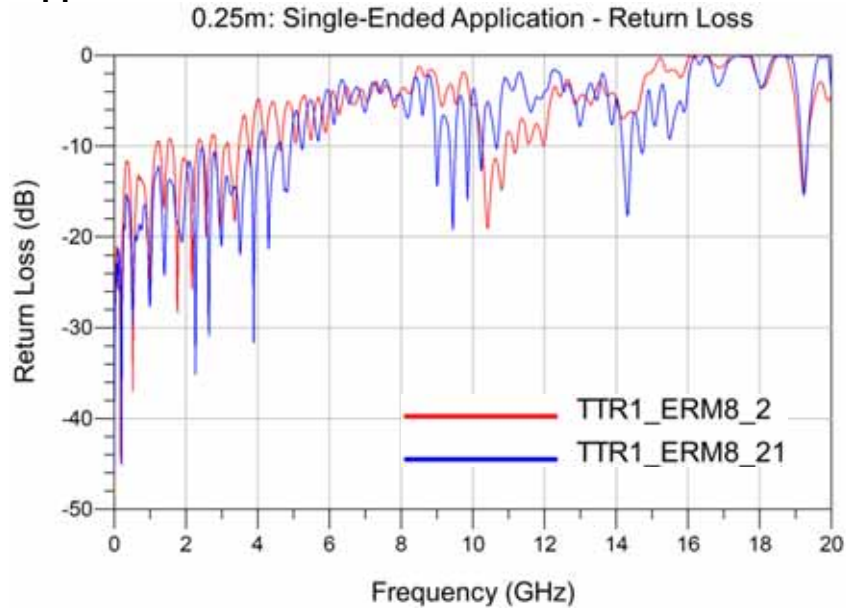

**Series:** (0.80 mm) .0315" ERCD

**Description:** 0.8mm Edge Rate High Speed Coax Cable Assembly

## Single Ended Application – NEXT Configurations

0.25m: Single-Ended Application - NEXT

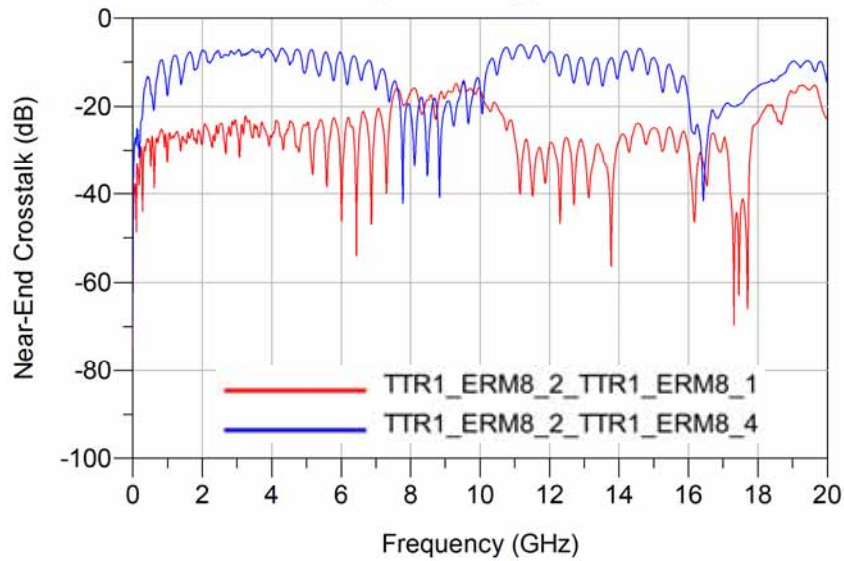

0.25m: Single-Ended Application - NEXT

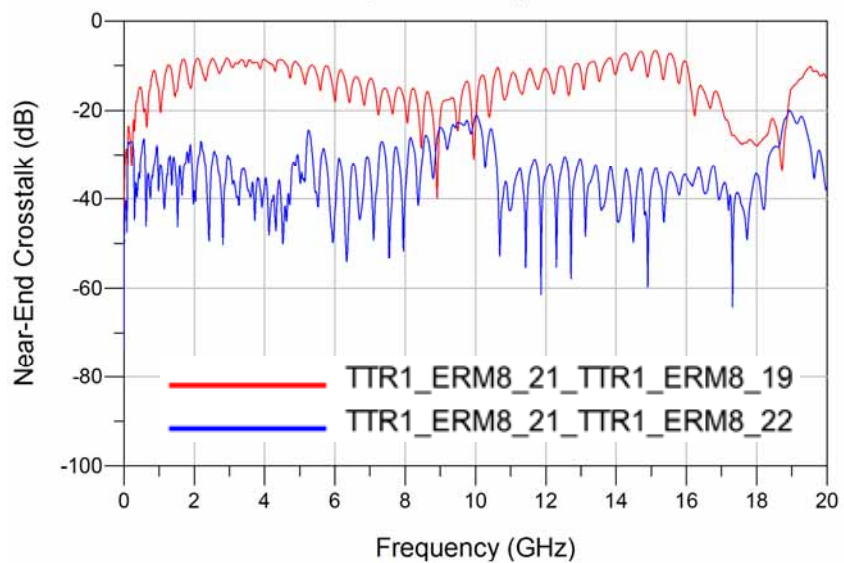

**Series:** (0.80 mm) .0315" ERCD

**Description:** 0.8mm Edge Rate High Speed Coax Cable Assembly

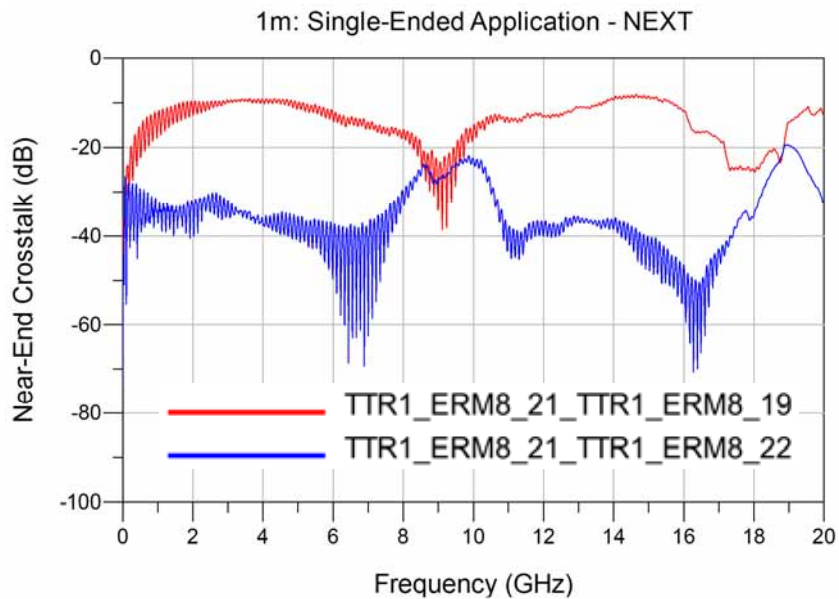
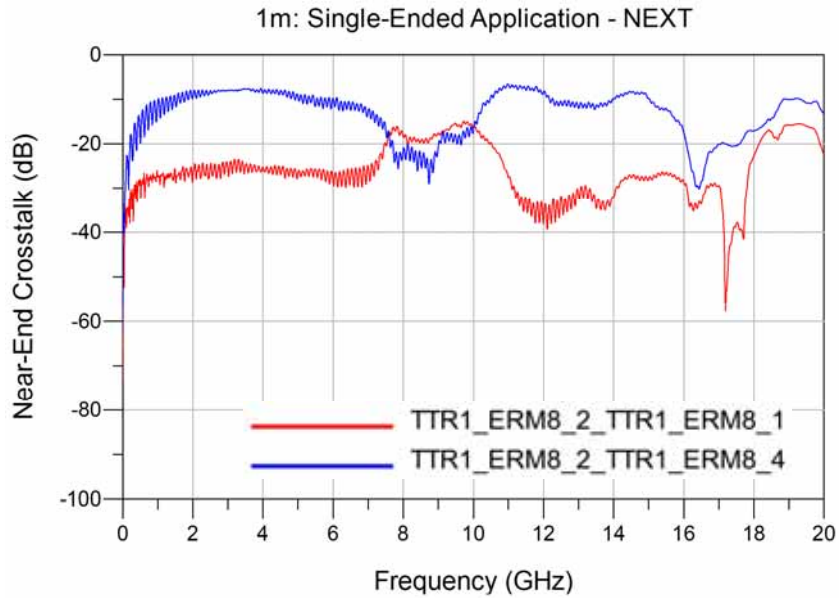

Series: (0.80 mm) .0315" ERCD

Description: 0.8mm Edge Rate High Speed Coax Cable Assembly

### Single Ended Application – FEXT Configurations

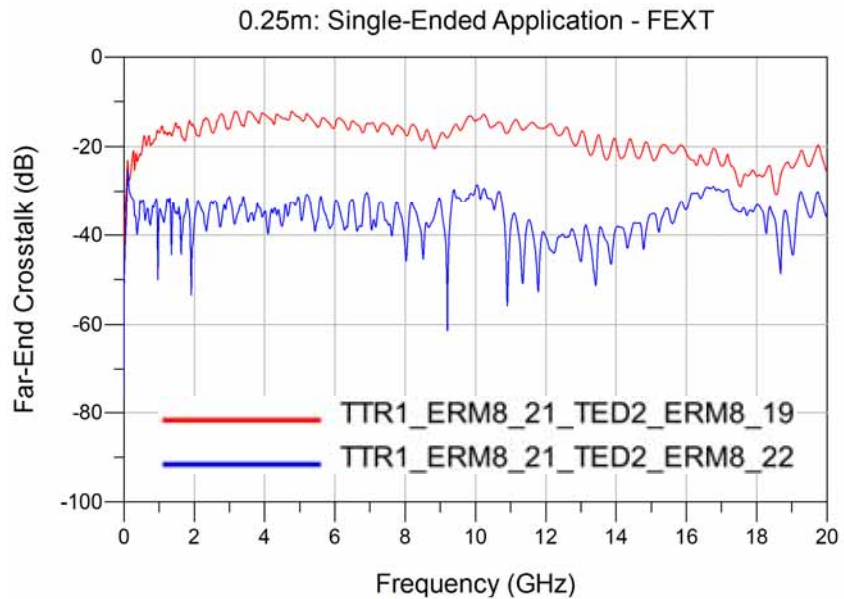
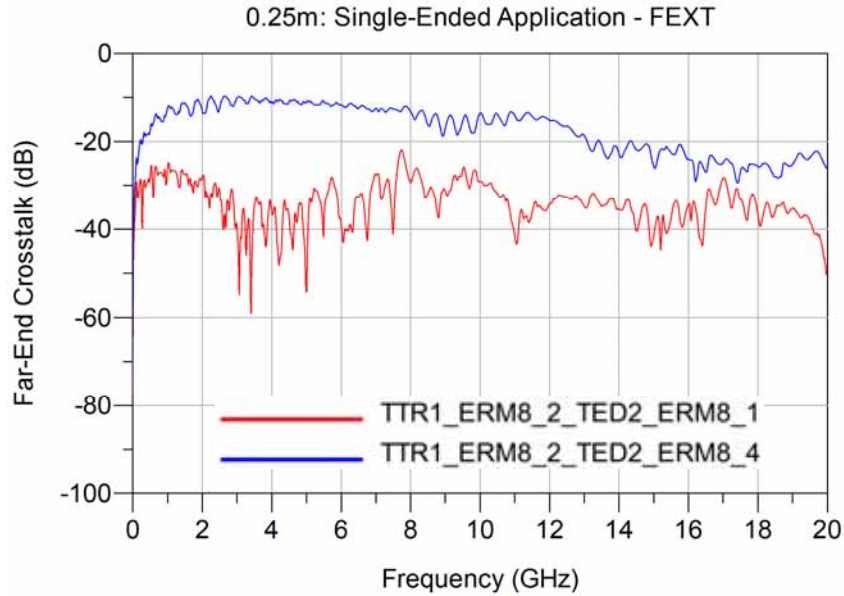

Series: (0.80 mm) .0315" ERCD

Description: 0.8mm Edge Rate High Speed Coax Cable Assembly

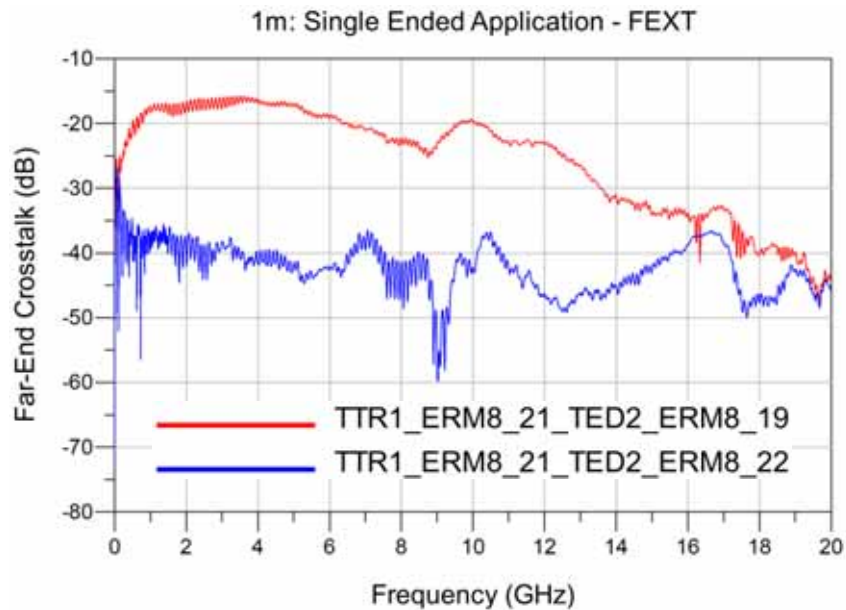
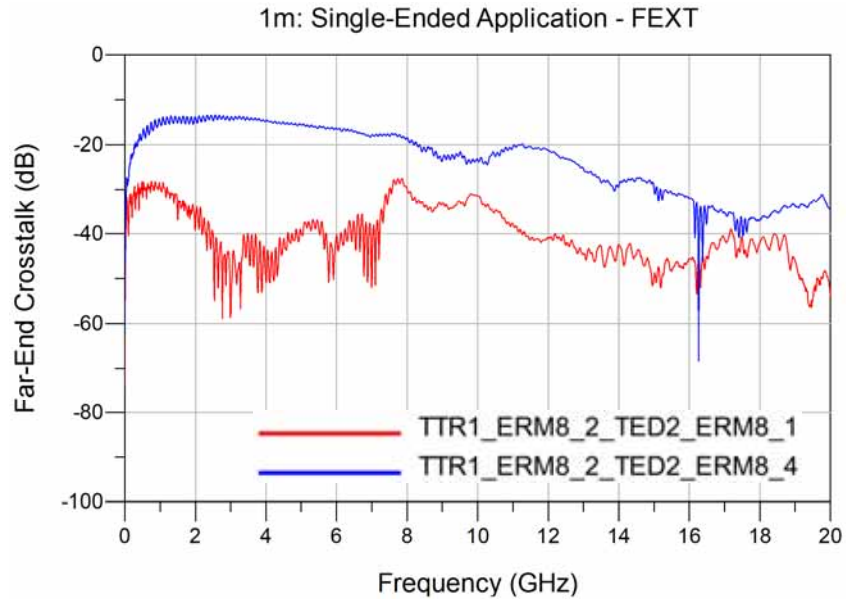

**Series:** (0.80 mm) .0315" ERCD

**Description:** 0.8mm Edge Rate High Speed Coax Cable Assembly

## Differential Application – Insertion Loss

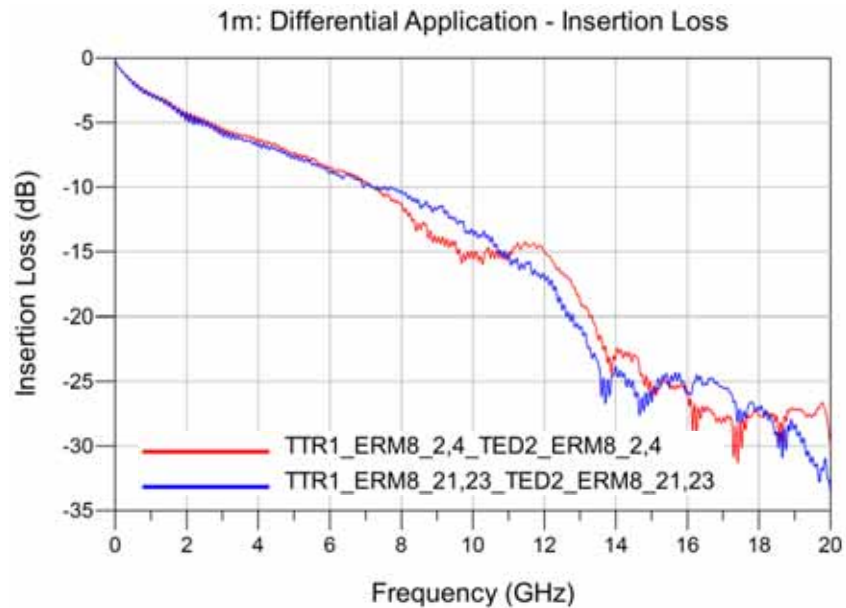
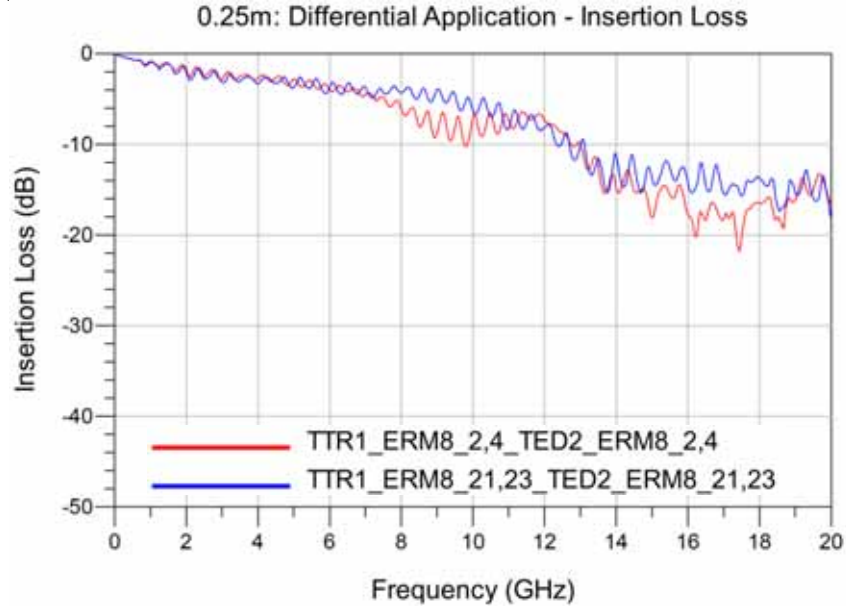

Series: (0.80 mm) .0315" ERCD

Description: 0.8mm Edge Rate High Speed Coax Cable Assembly

## Differential Application – Return Loss

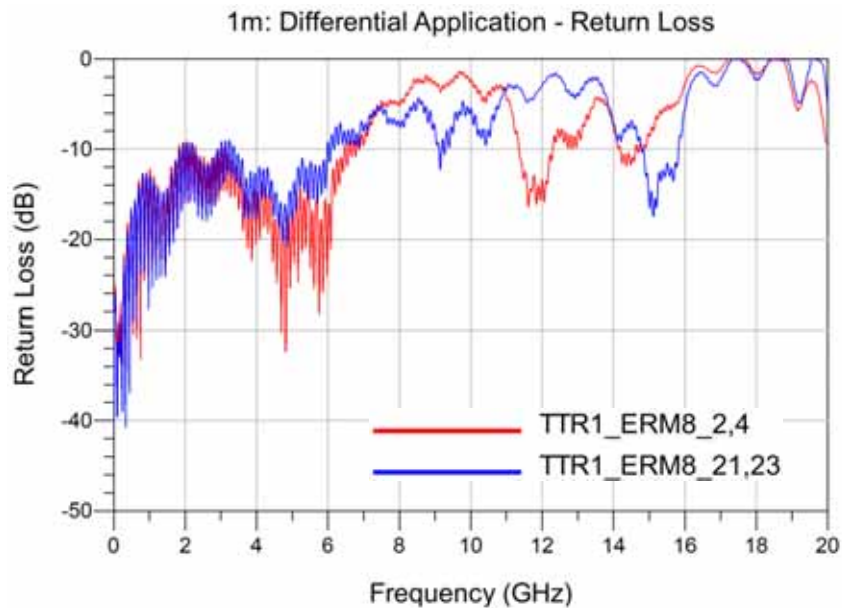
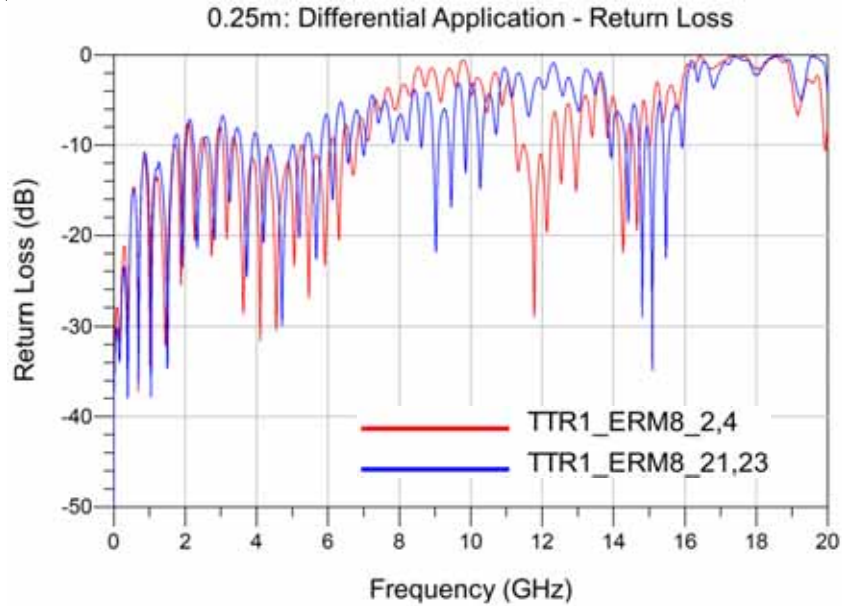

Series: (0.80 mm) .0315" ERCD

Description: 0.8mm Edge Rate High Speed Coax Cable Assembly

### Differential Application – NEXT Configurations

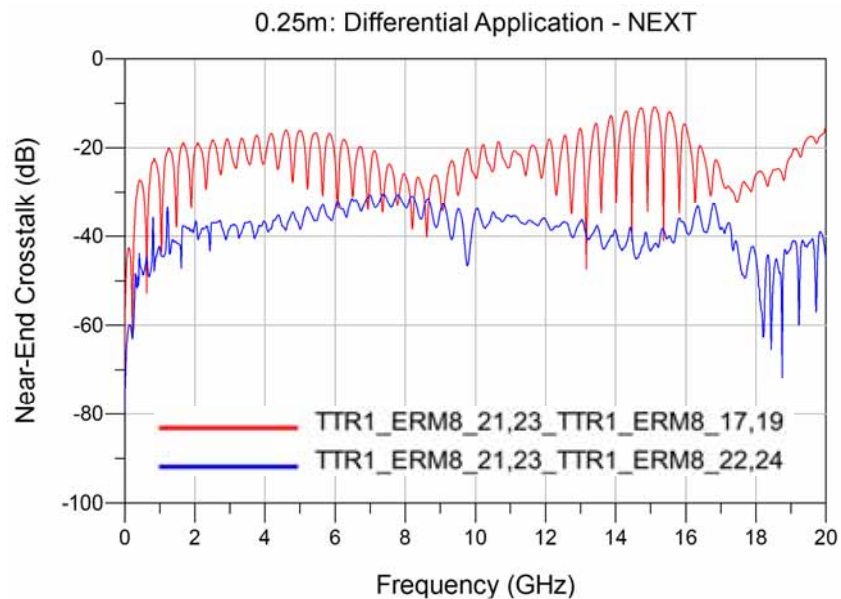
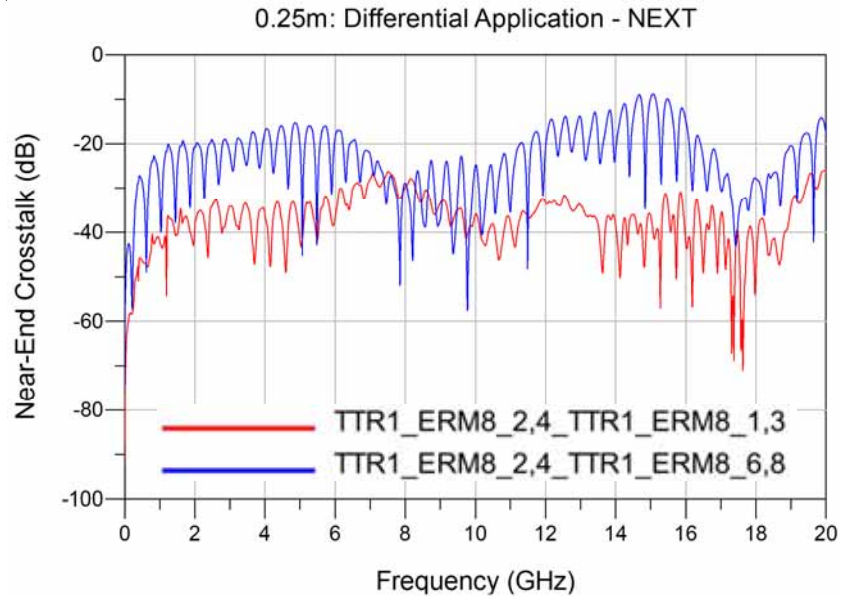

**Series:** (0.80 mm) .0315" ERCD

**Description:** 0.8mm Edge Rate High Speed Coax Cable Assembly

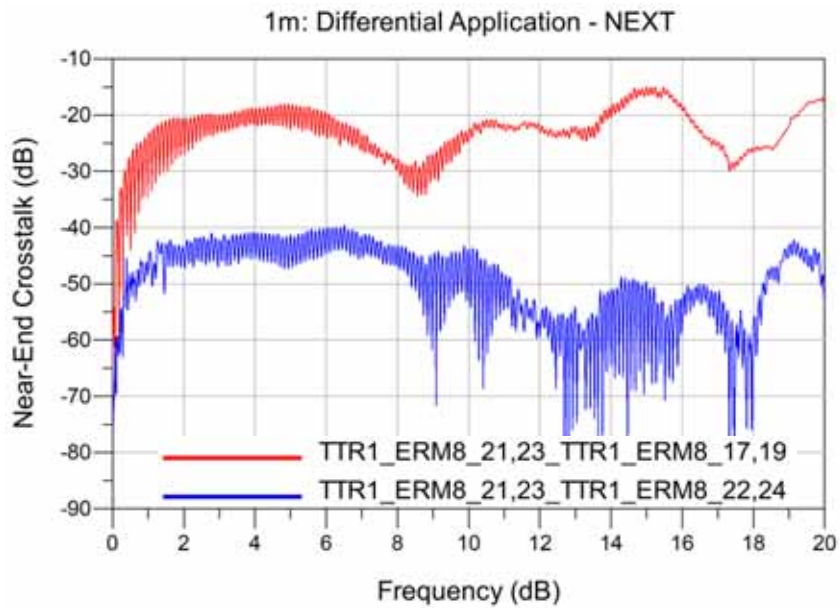
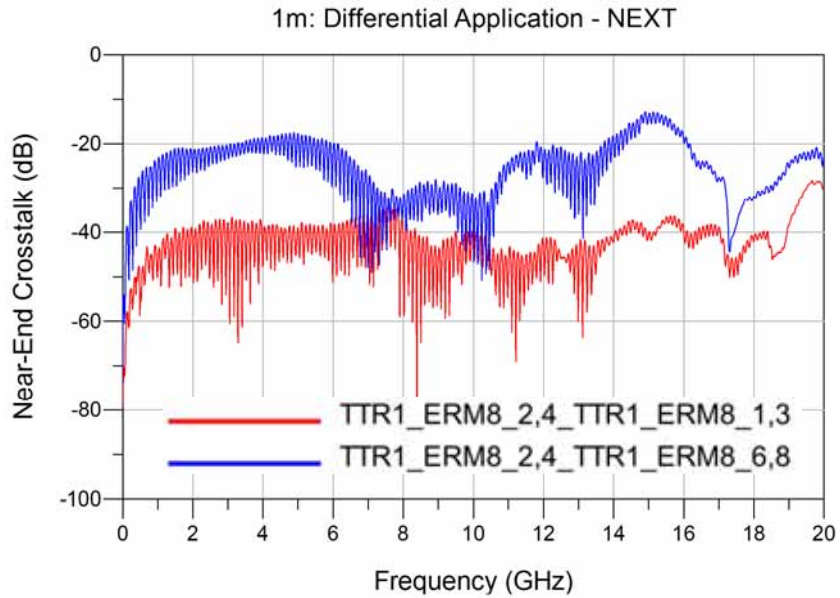

**Series:** (0.80 mm) .0315" ERCD

**Description:** 0.8mm Edge Rate High Speed Coax Cable Assembly

## Differential Application – FEXT Configurations

0.25m: Differential Application - FEXT

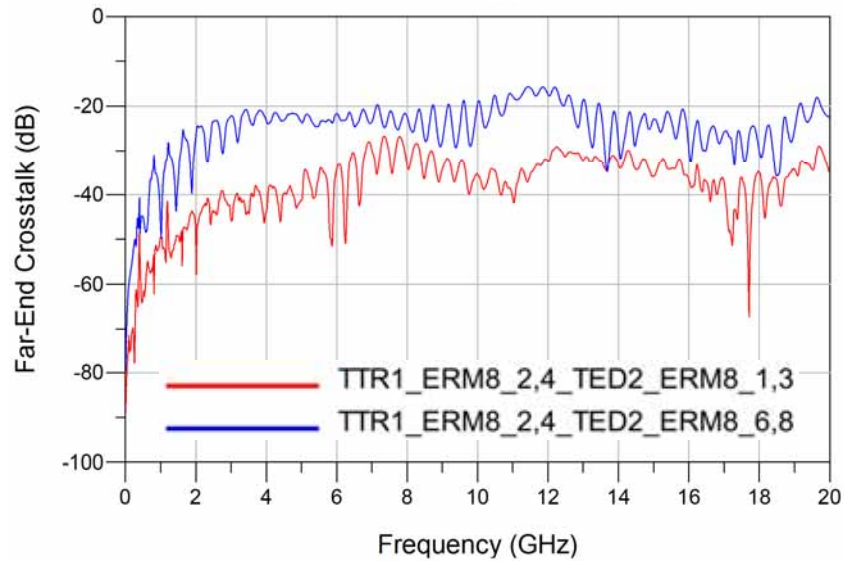

0.25m: Differential Application - FEXT

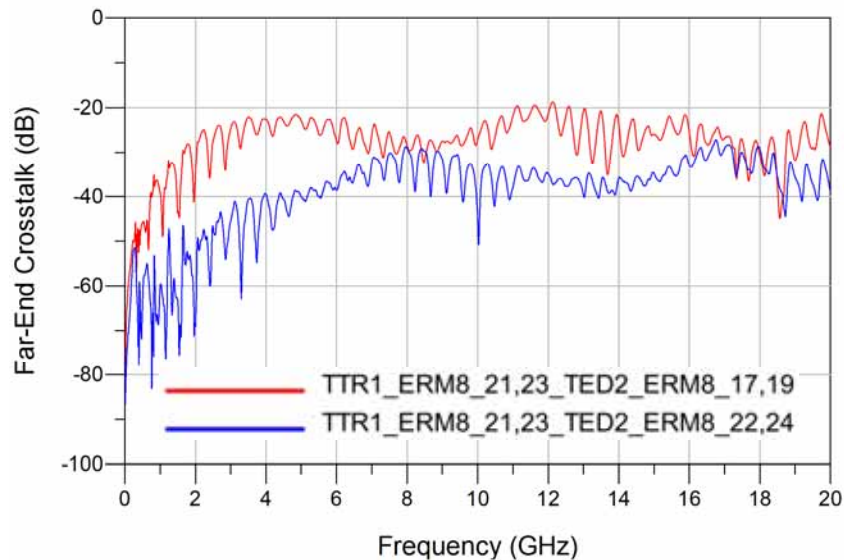

Series: (0.80 mm) .0315" ERCD

Description: 0.8mm Edge Rate High Speed Coax Cable Assembly

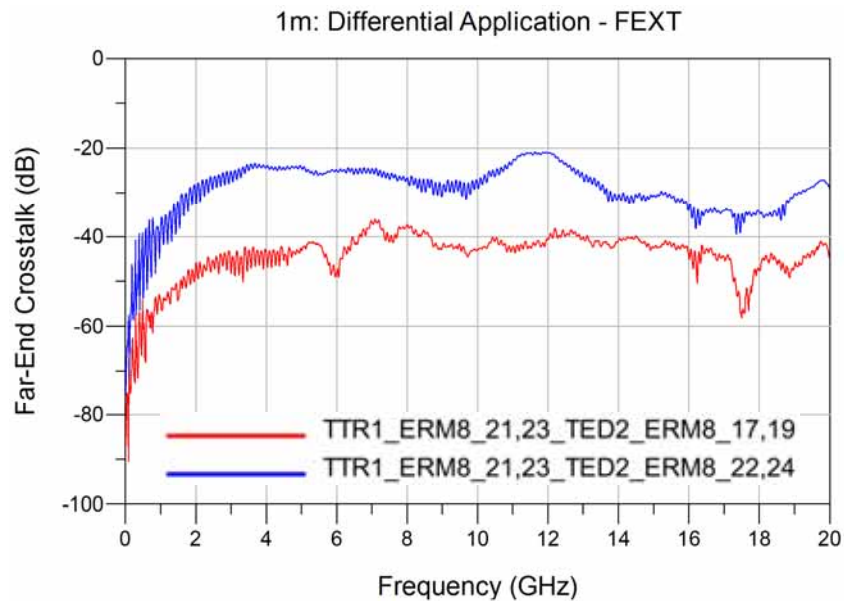
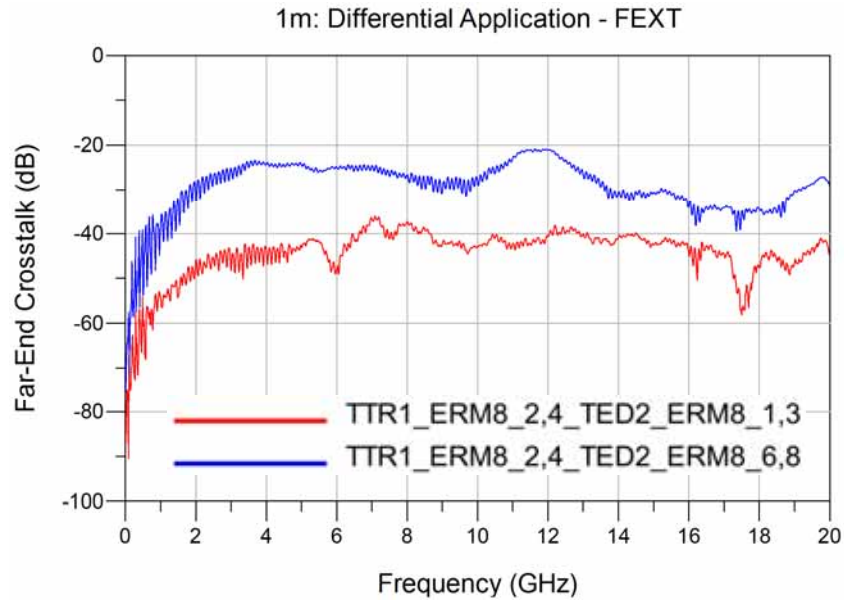

**Series:** (0.80 mm) .0315" ERCD

**Description:** 0.8mm Edge Rate High Speed Coax Cable Assembly

## Differential Application – Differential to Common Mode Conversion

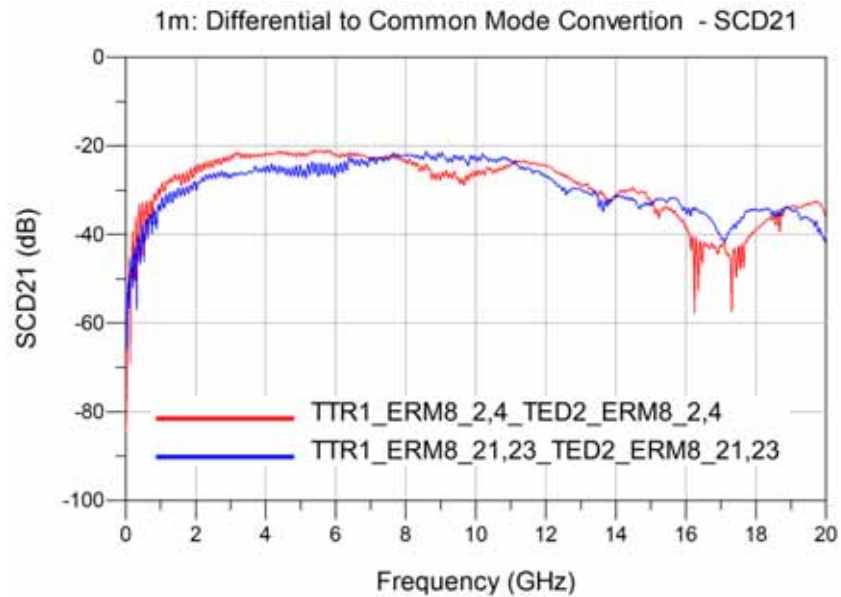
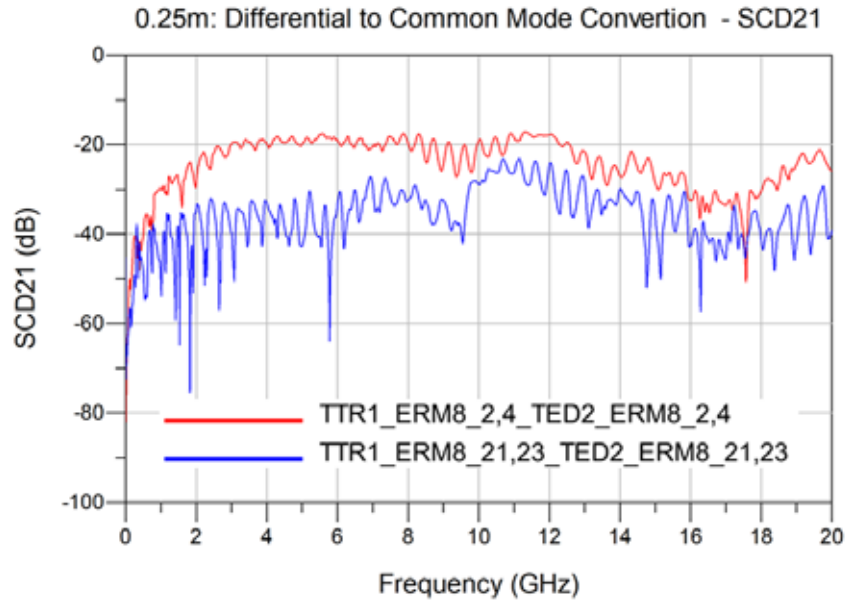

Series: (0.80 mm) .0315" ERCD

Description: 0.8mm Edge Rate High Speed Coax Cable Assembly

## Appendix C – Time Domain Response Graphs

### Single Ended Application – Input Pulse

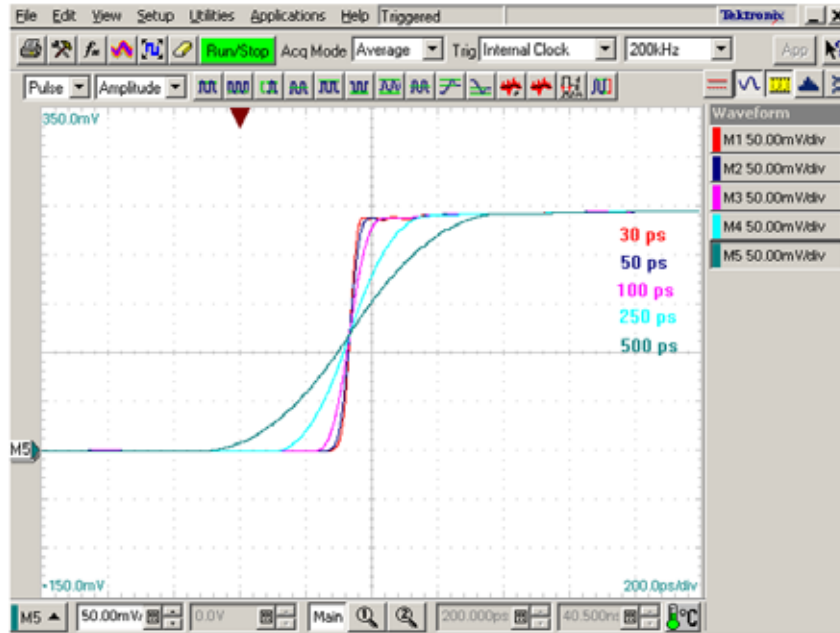

### Single Ended Application – Cable Assembly Impedance

0.25m : Single Ended Application \_ Impedance

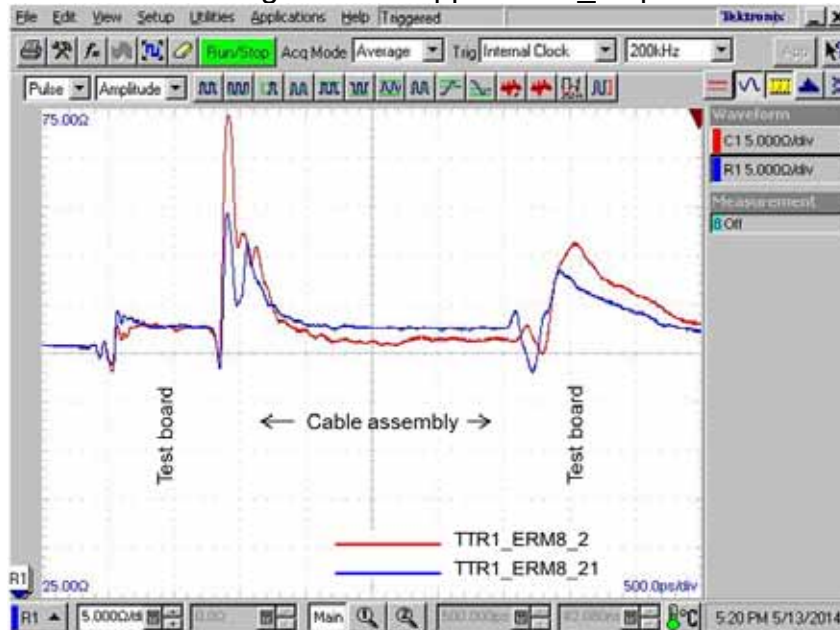

**Series:** (0.80 mm) .0315" ERCD

**Description:** 0.8mm Edge Rate High Speed Coax Cable Assembly

## 1m : Single Ended Application \_ Impedance

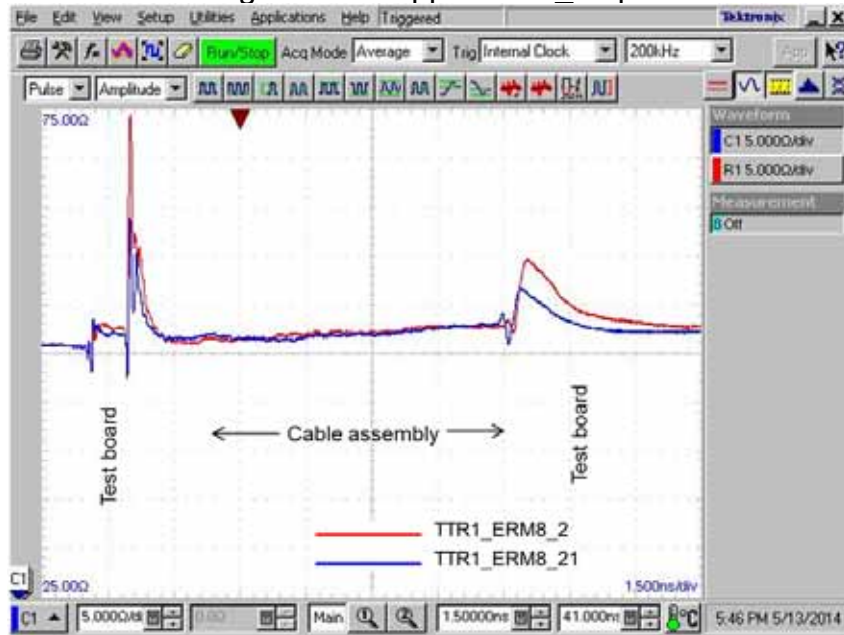

## Single Ended Application – Cable assembly Impedance

ERCD\_020\_09.80\_TTR\_TED\_1\_D

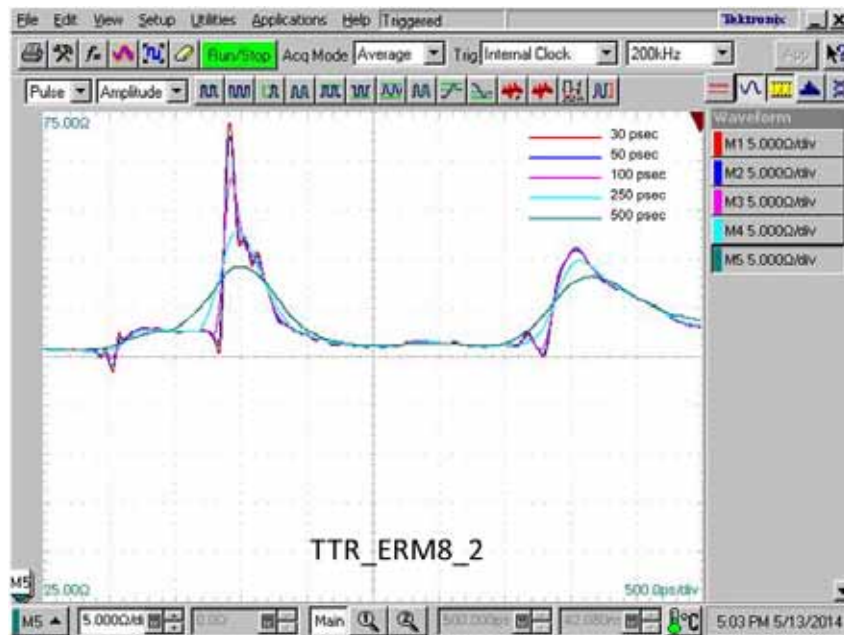

Series: (0.80 mm) .0315" ERCD

Description: 0.8mm Edge Rate High Speed Coax Cable Assembly

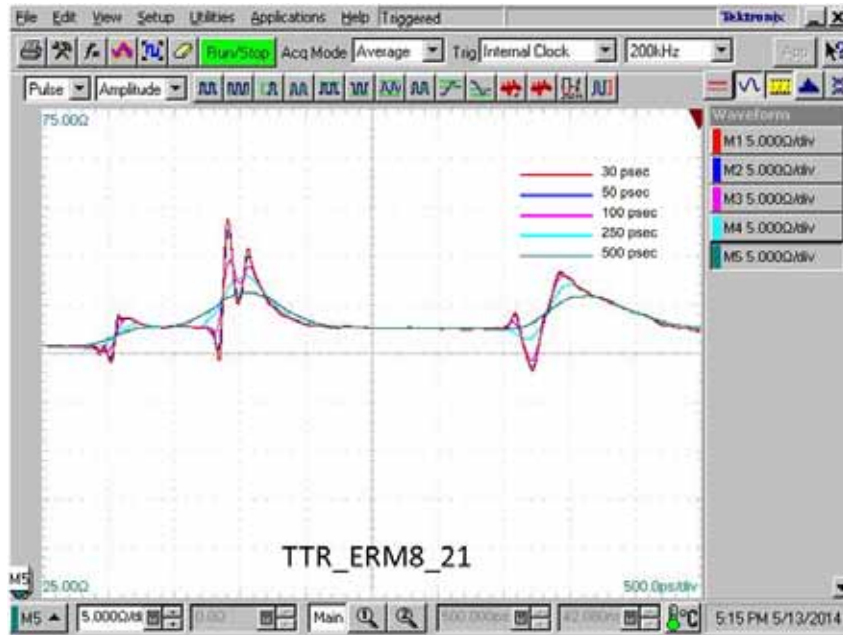

ERCD\_020\_39.37\_TTR\_TED\_1\_D

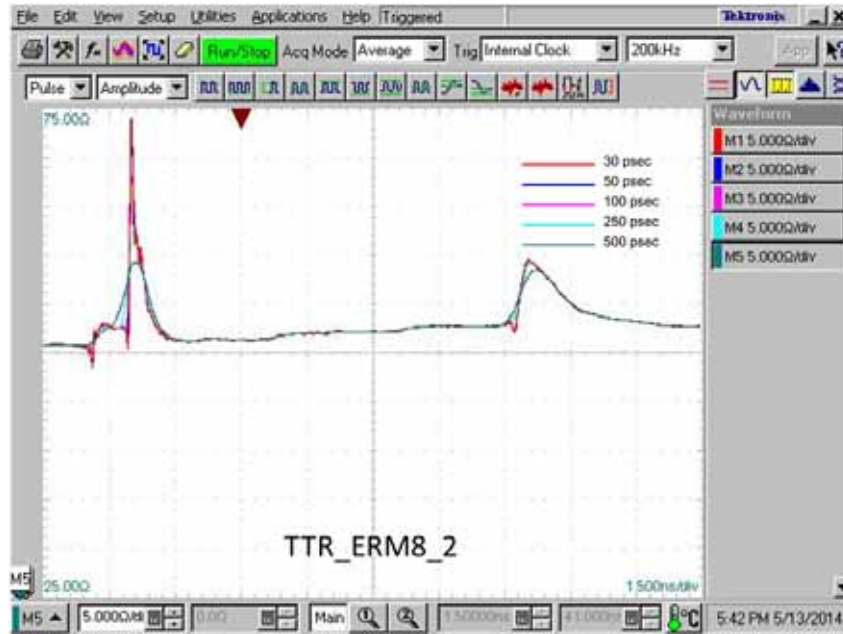

**Series:** (0.80 mm) .0315" ERCD

**Description:** 0.8mm Edge Rate High Speed Coax Cable Assembly

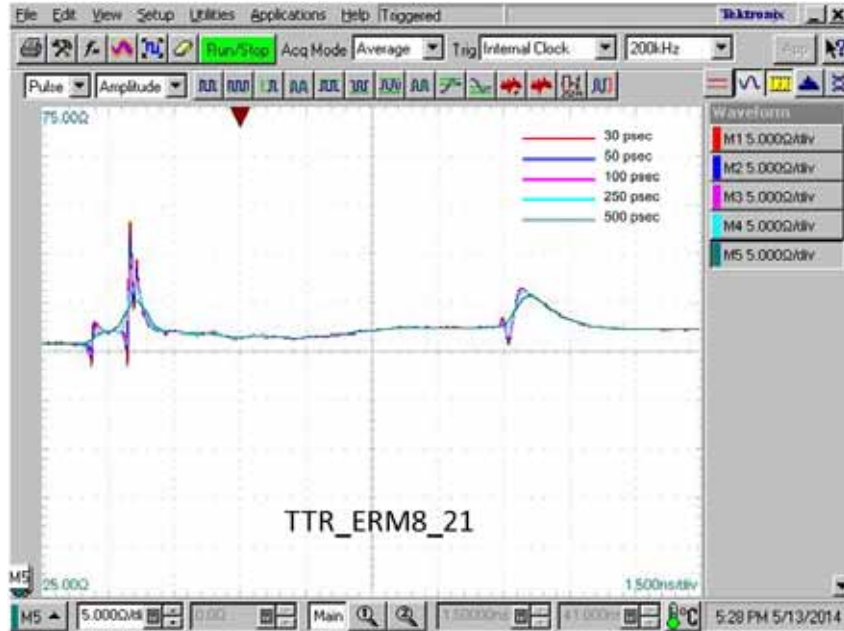

## Single Ended Application – Propagation Delay

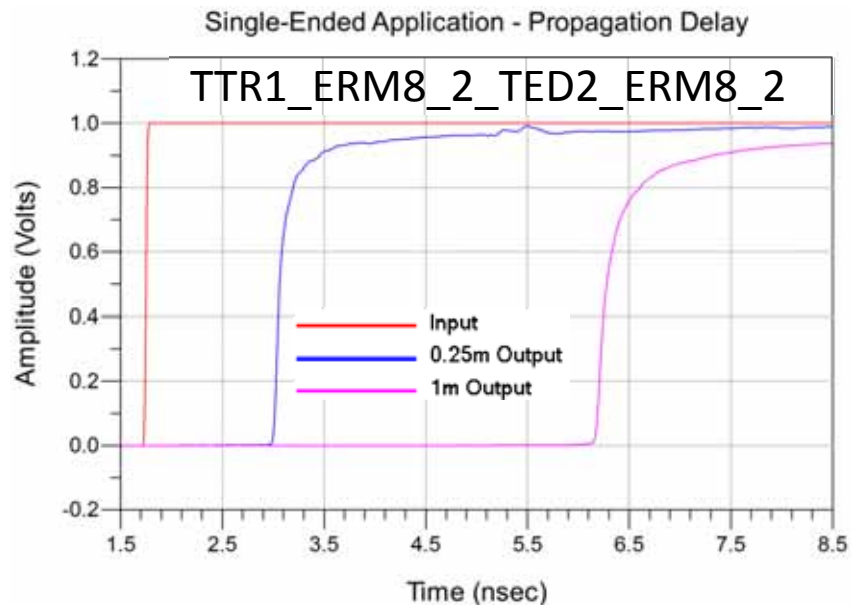

**Series:** (0.80 mm) .0315" ERCD

**Description:** 0.8mm Edge Rate High Speed Coax Cable Assembly

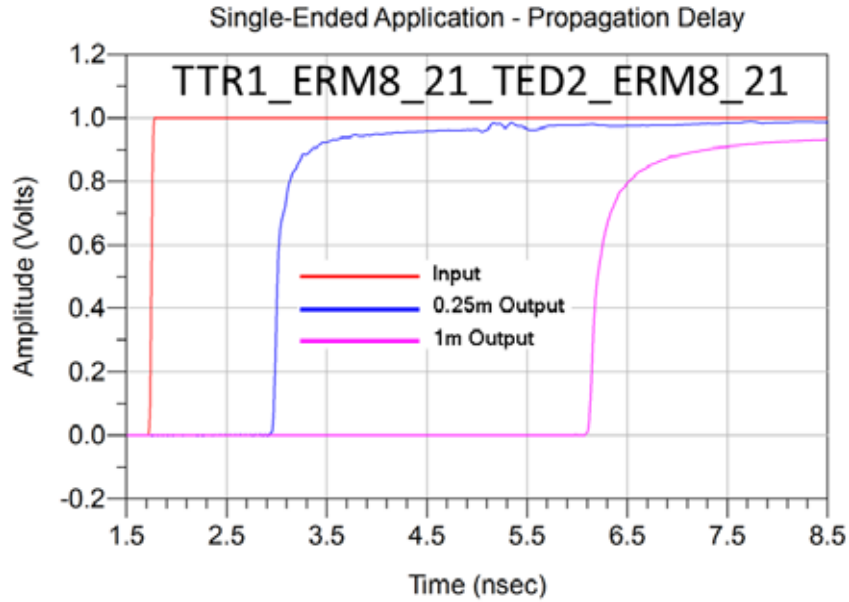

Series: (0.80 mm) .0315" ERCD

Description: 0.8mm Edge Rate High Speed Coax Cable Assembly

## Differential Application – Input Pulse

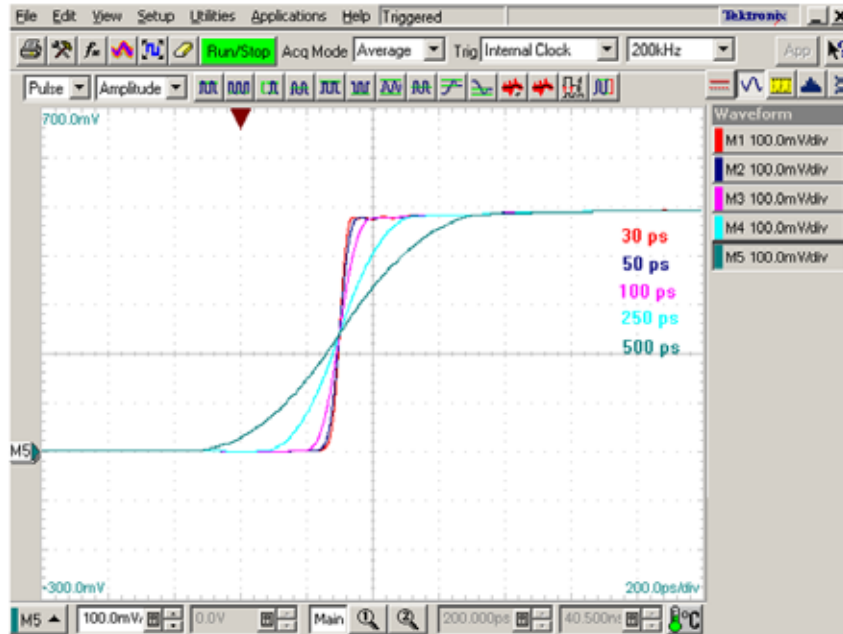

## Differential Application – Cable Assembly Impedance

0.25m : Differential Application \_ Impedance

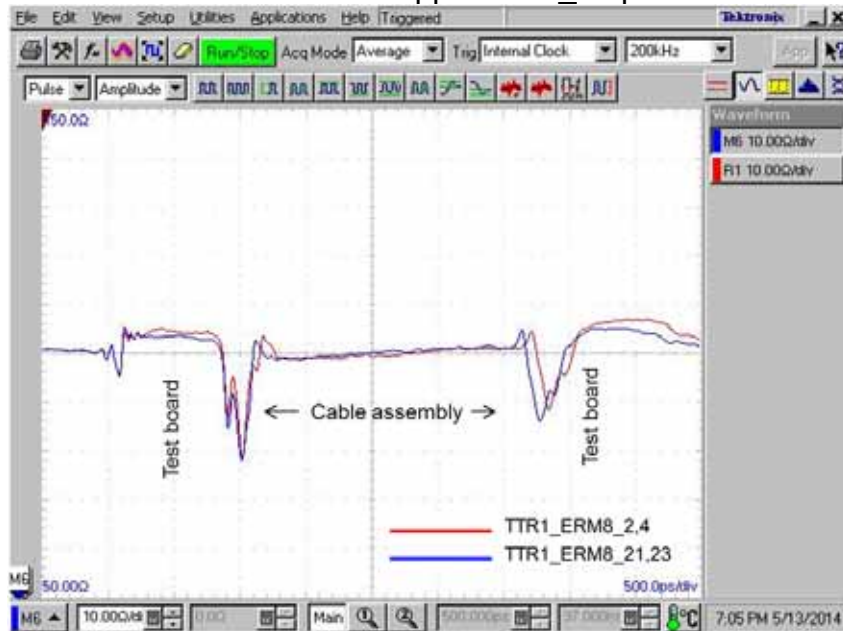

**Series:** (0.80 mm) .0315" ERCD

**Description:** 0.8mm Edge Rate High Speed Coax Cable Assembly

## 1m : Differential Application \_ Impedance

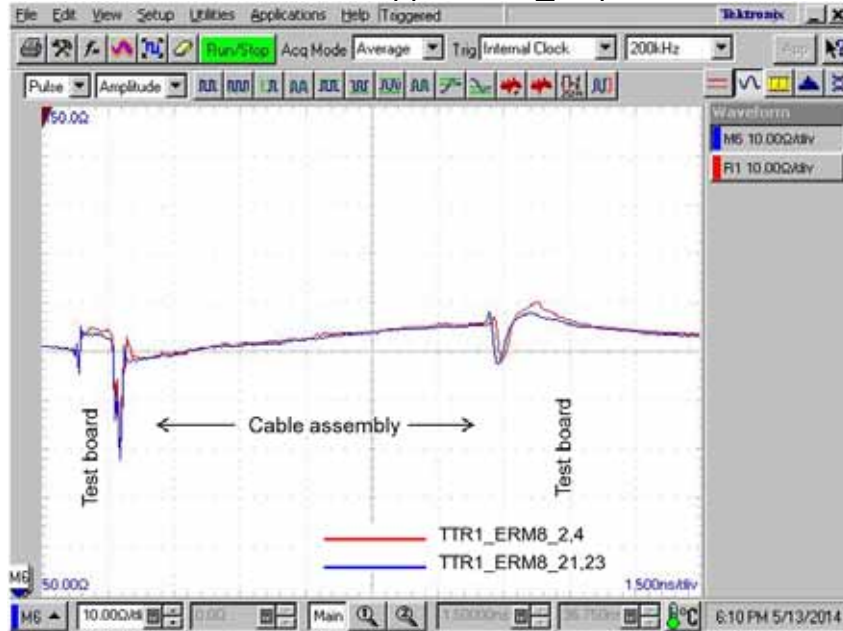

## Differential Application – Cable assembly Impedance

ERCD\_020\_09.80\_TTR\_TED\_1\_D

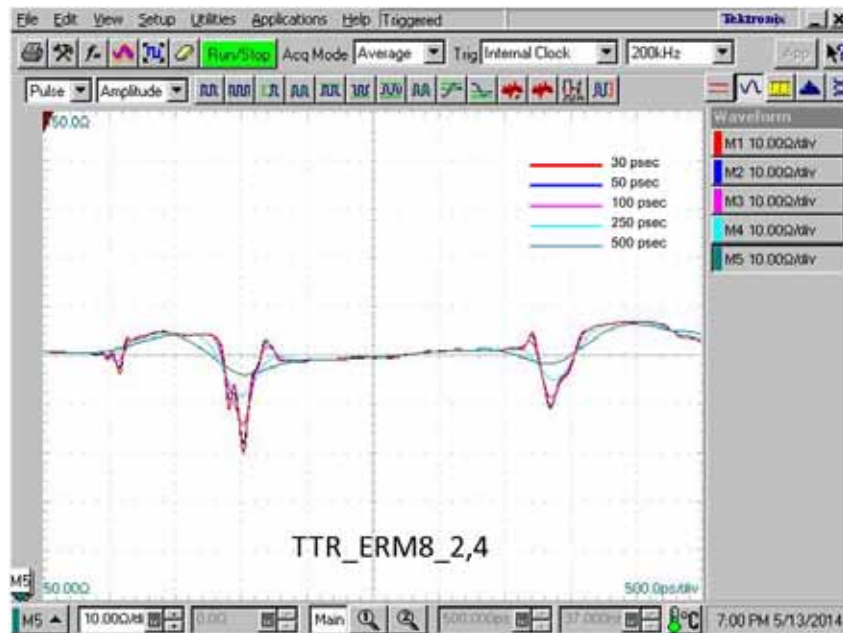

Series: (0.80 mm) .0315" ERCD

Description: 0.8mm Edge Rate High Speed Coax Cable Assembly

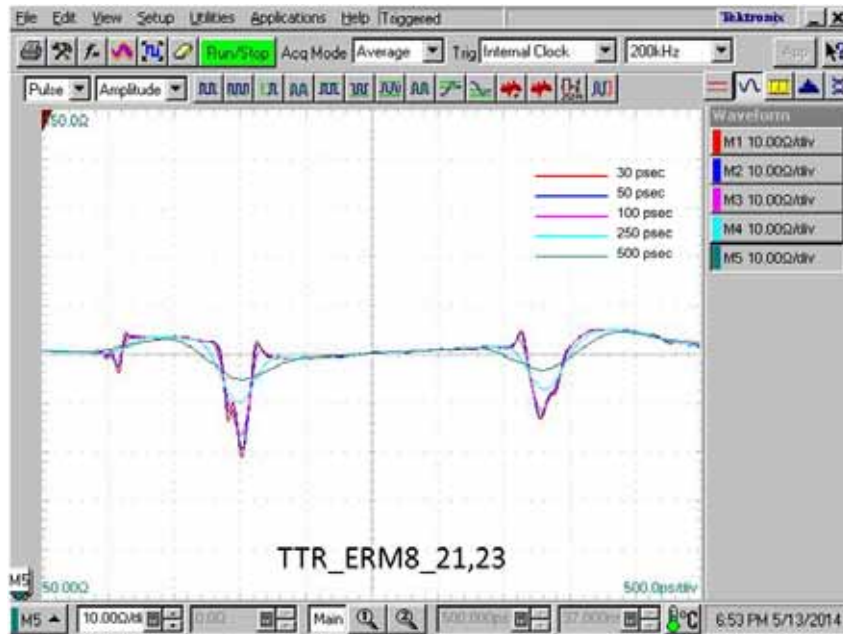

ERCD\_020\_39.37\_TTR\_TED\_1\_D

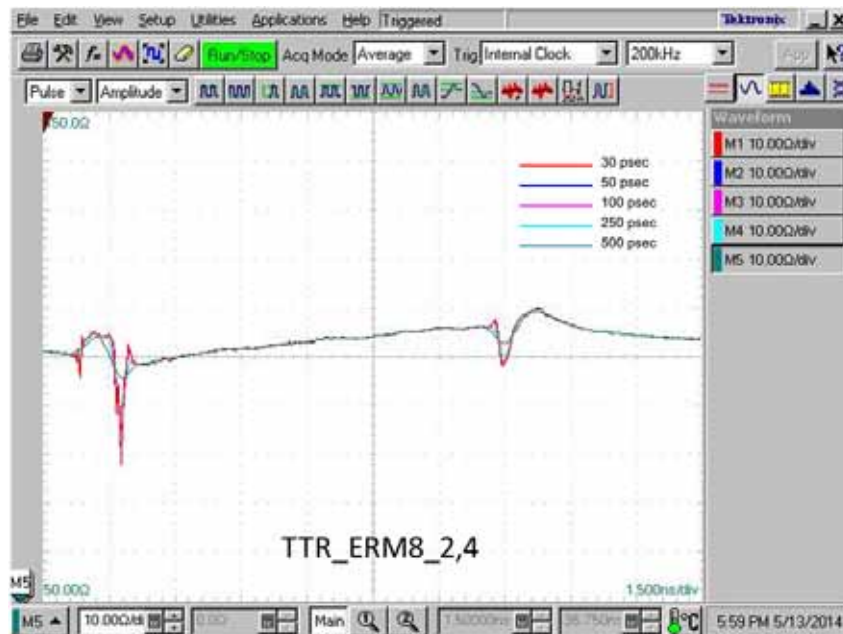

**Series:** (0.80 mm) .0315" ERCD

**Description:** 0.8mm Edge Rate High Speed Coax Cable Assembly

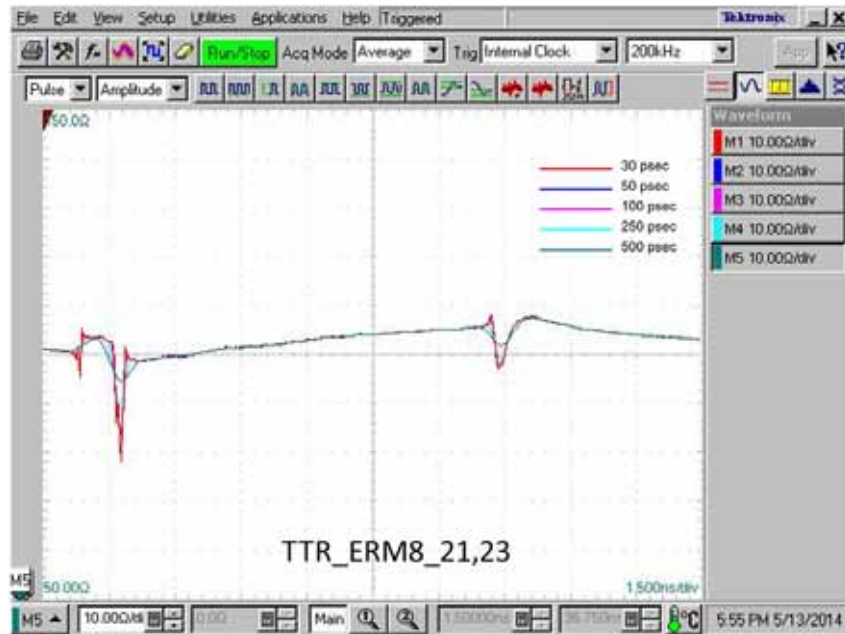

## Differential Application – Propagation Delay

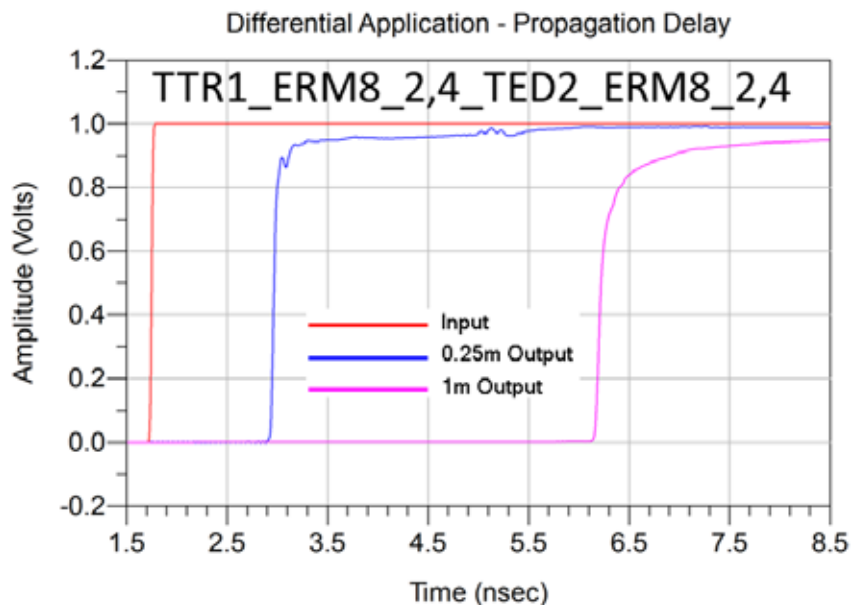

**Series:** (0.80 mm) .0315" ERCD

**Description:** 0.8mm Edge Rate High Speed Coax Cable Assembly

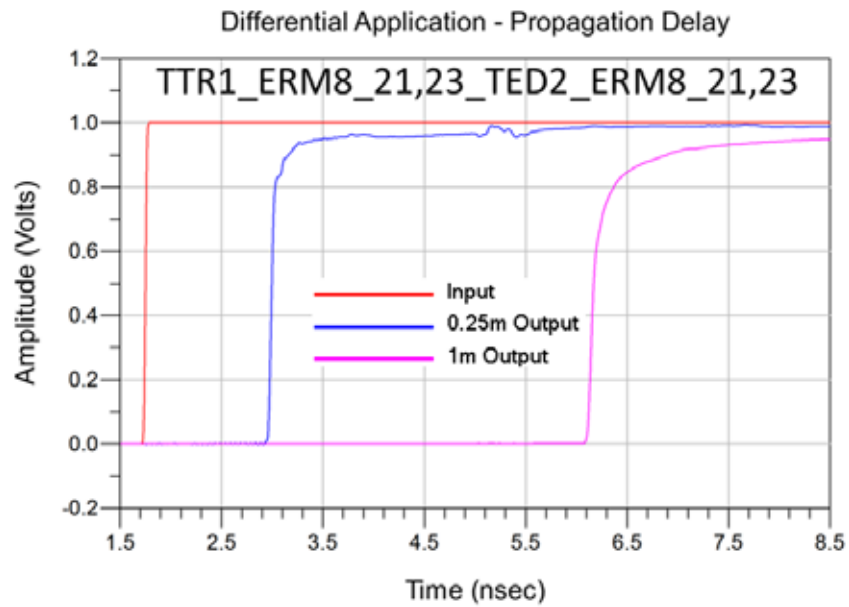

**Series:** (0.80 mm) .0315" ERCD

**Description:** 0.8mm Edge Rate High Speed Coax Cable Assembly

## Appendix D – Product and Test System Descriptions

### Product Description

Product test samples are 0.8mm Edge Rate High Speed coax cable assemblies. The part numbers are ERCD\_020\_09.80\_TTR\_TED\_1\_D and ERCD\_020\_39.37\_TTR\_TED\_1\_D, they mate with ERF8-020-05.0-S-DV-L. The cable assembly has two rows of 20 contacts evenly spaced on a 0.8 mm (0.0315") pitch. A photo of the mated test article mounted to SI test boards is shown below.

The coax cable assembly terminations had a particular signal line configuration. The respective signal line numbers are shown in table below. There are a total of 20 positions per row. SMA jack numbers on the test boards correspond to the assembly line numbers. All adjacent lines are terminated where applicable.

1	3	5	7	G	G	G	G	17	19	21	23	25	G	G	G	33	35	37	39
2	4	6	8	G	G	G	G	18	20	22	24	26	G	G	G	34	36	38	40

**Table 5: Respective signal line numbers**

### Test System Description

The test fixtures are composed of four-layer IT180 material with 50Ω signal trace and pad configurations designed for the electrical characterization of Samtec high speed cable assembly products. A PCB mount SMA connector is used to interface the VNA test cables to the test fixtures. Optimization of the SMA launch was performed using full wave simulation tools to minimize reflections. Two test fixture specific to the ERCD series cable assembly identified by part PCB-105949-SIG-01A and PCB-105949-SIG-02C. The Auto Fixture Removal (AFR) calibration structures designed specifically for the ERCD series are on the same test fixture. Displayed on the following pages is information for the ERCD/AFR calibration structure and directives for mating ERCD fixtures.

### PCB-105949-SIG-XX Test Fixtures

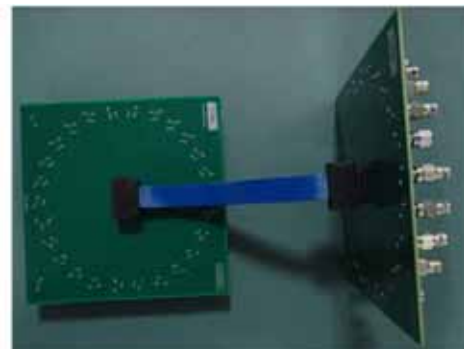
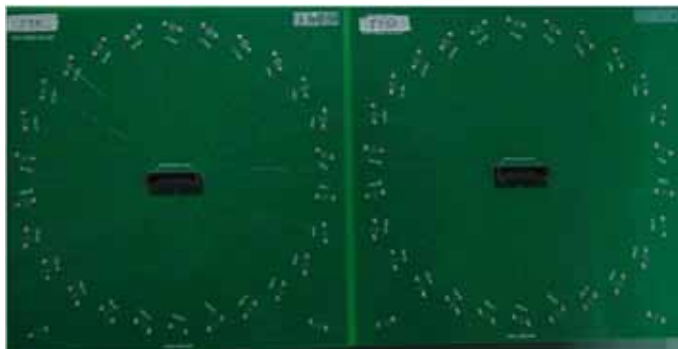

**Series:** (0.80 mm) .0315" ERCD

**Description:** 0.8mm Edge Rate High Speed Coax Cable Assembly

Artwork of the PCB design is shown below.

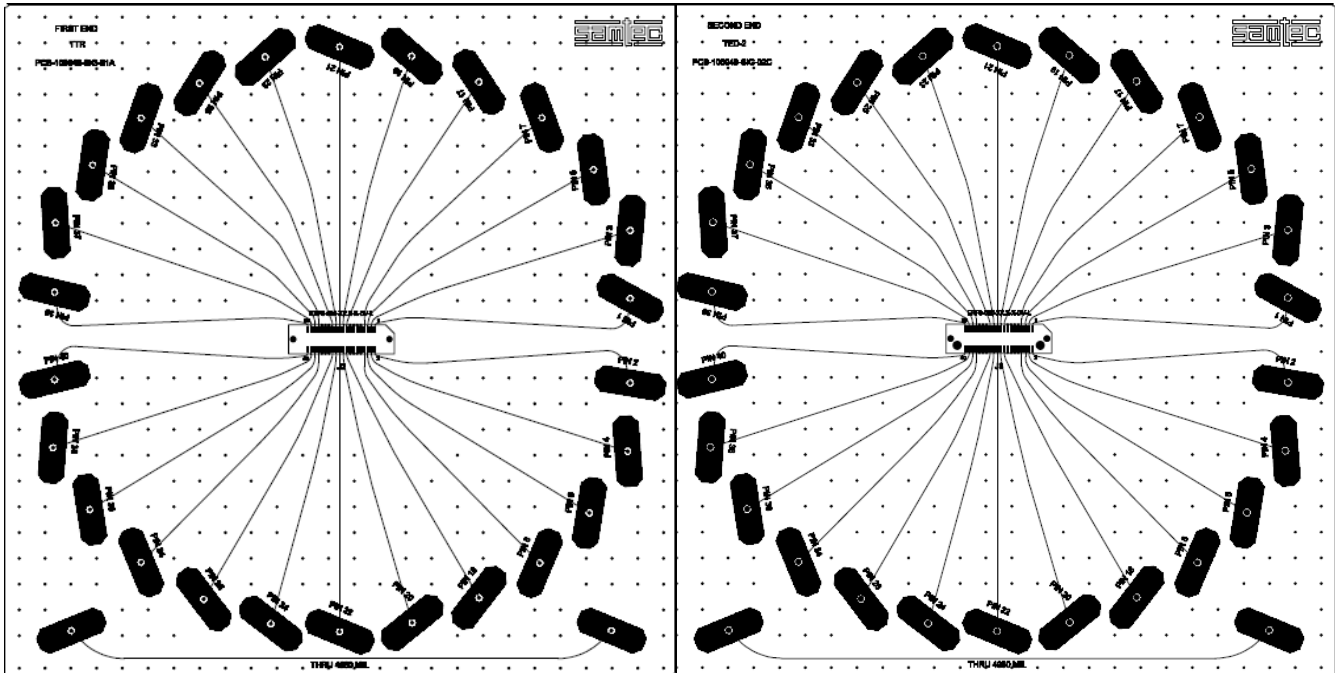

### PCB Fixtures

The test fixtures used are as follows:

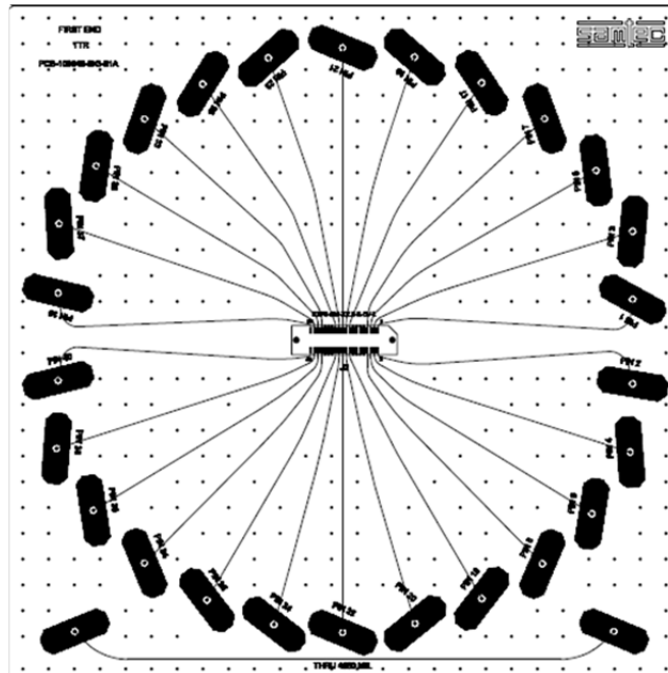

**Series:** (0.80 mm) .0315" ERCD

**Description:** 0.8mm Edge Rate High Speed Coax Cable Assembly

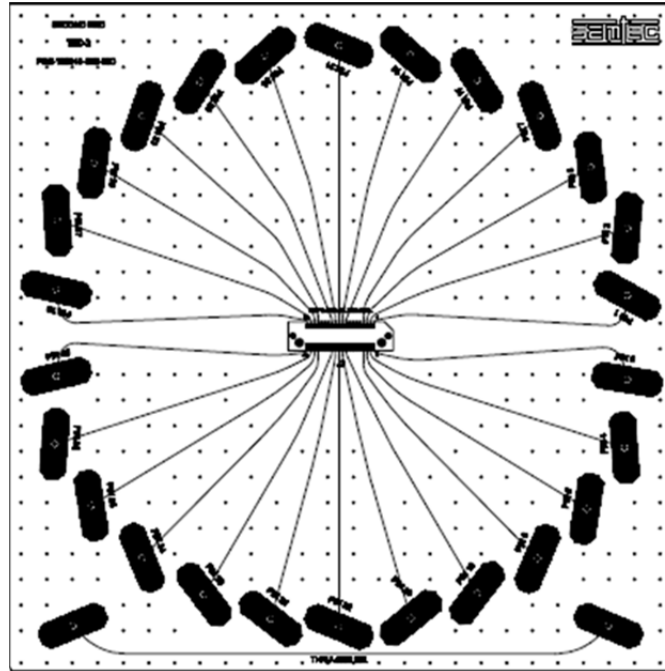

PCB-105949-SIG-01A – First End TTR  
PCB-105949-SIG-02C – Second End TED

**Series:** (0.80 mm) .0315" ERCD

**Description:** 0.8mm Edge Rate High Speed Coax Cable Assembly

## Appendix E – Test and Measurement Setup

The test instrument is the Agilent N5230C PNA-L network analyzer. Frequency domain data and graphs are obtained directly from the instrument. Post-processed time domain data and graphs are generated using convolution algorithms within Agilent ADS. The network analyzer is configured as follows:

Start Frequency – 300 KHz

Number of points -1601

Stop Frequency – 20 GHz

IFBW – 1 KHz

With these settings, the measurement time is approximately 20 seconds.

### N5230C Measurement Setup

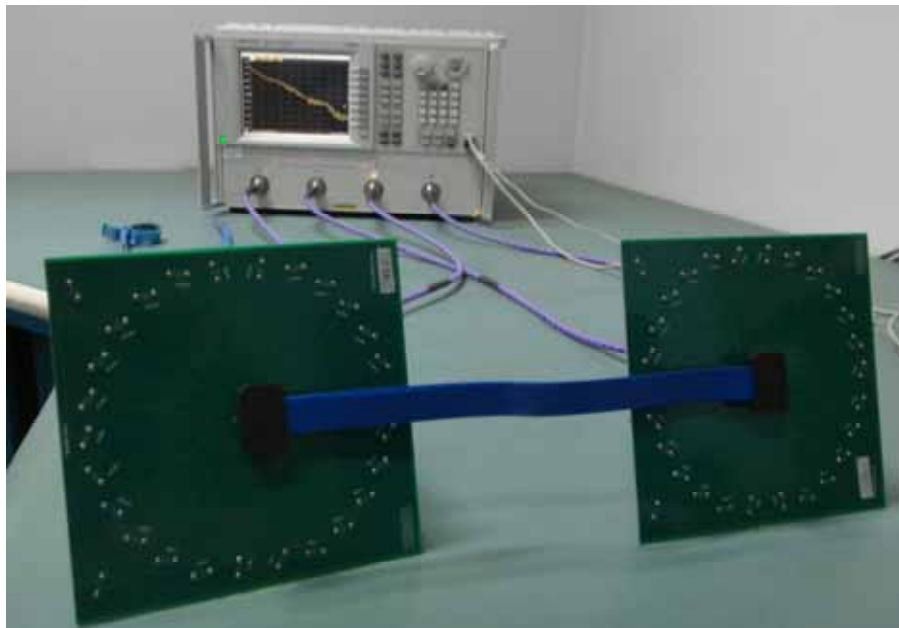

### Test Instruments

<u>QTY</u>	<u>Description</u>
1	Agilent N5230C PNA-L Network Analyzer (300 KHz to 20 GHz)
1	Agilent N4433A ecal module (300 KHz to 20 GHz)

### Test Cables & Adapters

<u>QTY</u>	<u>Description</u>
4	Gore OWD01D02039-4 (DC-26.5 GHz)

**Series:** (0.80 mm) .0315" ERCD

**Description:** 0.8mm Edge Rate High Speed Coax Cable Assembly

For impedance measurements, the test instrument is the Tektronix DSA8200 Digital Serial Analyzer mainframe and 80E04 sampling module. The impedance data and profiles are obtained directly from the instrument. The Digital Analyzer is configured as follows:

Vertical Scale: 5 ohm / Div or 10 ohm / Div

Offset: Default / Scroll

Horizontal Scale: 500ps/ Div or 1.5ns/ Div

Record Length: 4000

Averages:  $\geq 16$

### DSA8200 Measurement Setup

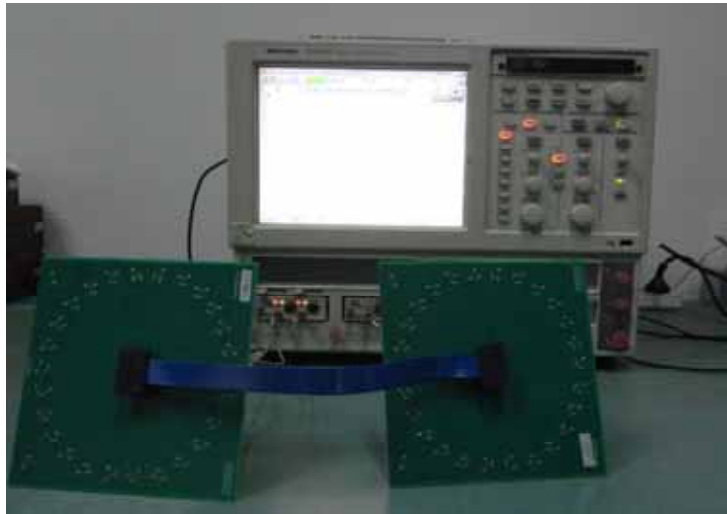

### Test Instruments

<u>QTY</u>	<u>Description</u>
1	Tektronix DSA8200 Digital Serial Analyzer
2	Tektronix 80E04 Dual Channel 20 GHz TDR Sampling Module

### Test Cables & Adapters

<u>QTY</u>	<u>Description</u>
2	Samtec RF405-01SP1-01SP1-0305 (DC-20 GHz)

**Series:** (0.80 mm) .0315" ERCD

**Description:** 0.8mm Edge Rate High Speed Coax Cable Assembly

## Appendix F - Frequency and Time Domain Measurements

### Eye Diagram Procedures

Eye Diagrams and statistical eye diagram metrics such as eye height can be generated by post-processing Frequency Domain measurements using Agilent ADS. Simulated data is sent over a touchstone model and the bits are overlain into an eye pattern.

Currently, no CEI specification is available for 7Gbps, so *CEI-28-VSR Working Clause Proposal, CEI Implementation agreement Draft 7.0*, dated May 14, 2012 was used for this report.

The simulation circuit is modeled as:

Agilent's Advanced Design System Tx and Rx modules that are configured to the *CEI-28-VSR Working Clause Proposal, CEI Implementation agreement Draft 7.0*, dated May 14, 2012.

- Tx parameters are specified in Section 1.3.3, *Module-to-Host Specifications*, Table 1-4, Page 7.
- Rx parameters defined in Section 1.3.2 *Host-to-Module Electrical Specifications*, Table 1-1, Page 5.
- A 1.0 inch length of Tx interconnect trace segment at the transmitter.
- SUT Cable Assembly S-Parameter measurements
  - 10 mils of 10.5 mil wide signal trace
  - Test board pads (footprint effects) for the ERF8 connector
  - The ERF8 series connector J1
  - The ERCD cable assembly
  - The ERF8 series connector J2
  - Test board pads (footprint effects) for the ERF8 connector
  - 10 mils of 10.5 mil wide signal trace
- A 1.0 inch length of Rx interconnect trace segment at the receiver.

All traces were modeled as microstrip on FR4 with the following parameters:

- The FR4 parameters are modeled using:
  - $E_r = 3.7 @ 1 \text{ GHz}$
  - Loss Tangent =  $0.02 @ 1 \text{ GHz}$
- Copper is modeled as:
  - Conductivity =  $4.5E+7 \text{ S-m}$
  - Surface roughness = 0.6 micron

**Series:** (0.80 mm) .0315" ERCD

**Description:** 0.8mm Edge Rate High Speed Coax Cable Assembly

- Traces are microstrip with the following geometry:
  - 10.5 mil trace width
  - 2 mil trace copper thickness
  - 5.8 mil FR4 dielectric thickness

### Eye Mask

The eye mask is set for 50mVpp, with a jitter margin of 0.5 UI.

### Rise Time

The 10-90 risetime of the 22Gbps signal was determined to be 16 psec, using the following formula:

$$\text{Risetime} = 0.35/\text{Bandwidth}$$

**Series:** (0.80 mm) .0315" ERCD

**Description:** 0.8mm Edge Rate High Speed Coax Cable Assembly

### Frequency (S-Parameter) Domain Procedures

The quality of any data taken with a network analyzer is directly related to the quality of the calibration standards and the use of proper test procedures. For this reason, extreme care is taken in the design of the AFR calibration standards, the SI test boards, and the selection of the PCB vendor.

The measurement process begins with a measurement of the AFR calibration standards. A coaxial SOLT calibration is performed using an N4433A E-cal module. This measurement is required in order to obtain precise values of the line standard offset delay and frequency bandwidths. Measurements of the 2x through line standard can be used to determine the maximum frequency for which the calibration standards are valid. For the ERCD test boards, this is greater than 20 GHz.

The figure below shows how the THRU reference traces are utilized to compensate for the losses due to the coaxial test cables and the test fixture during testing. The calibration board is characterized to obtain parameters required to define the 2x Thru.

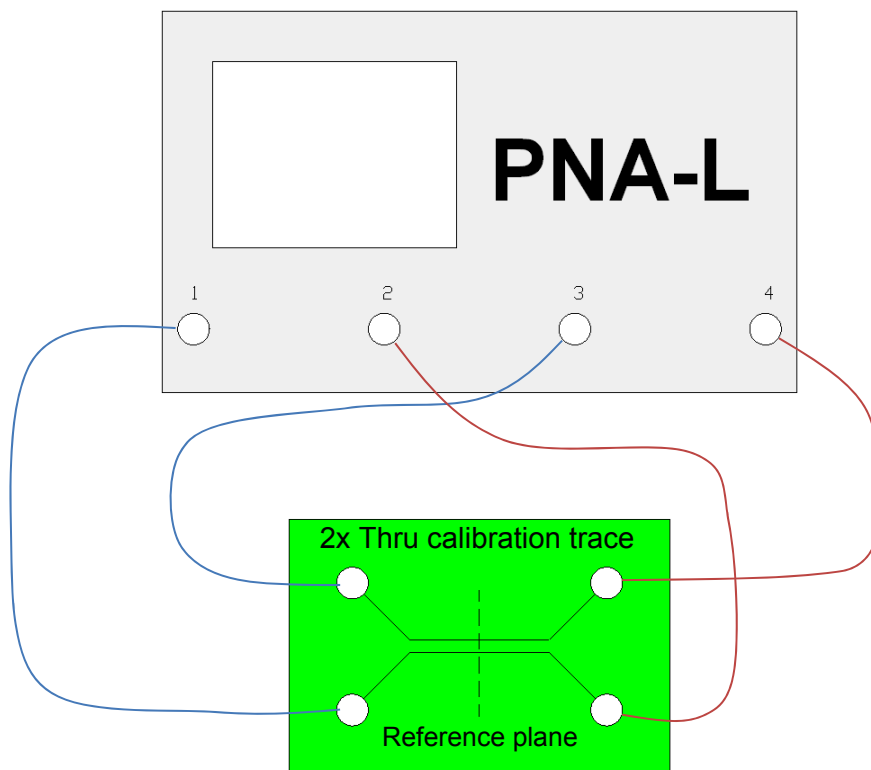

**Series:** (0.80 mm) .0315" ERCD

**Description:** 0.8mm Edge Rate High Speed Coax Cable Assembly

Measurements are then performed using the test boards as shown below. The test board effects are removed in post-processing via AFR in Agilent PLTS. The calibrated reference plane is located 10 mils from the connector footprint on each side. The S-Parameter measurements include:

- A. 10 mils of 10.5 mil wide signal trace
- B. Test board pads (footprint effects) for the ERF8 connector
- C. The ERF8 series connector J1
- D. The ERCD test cable
- E. The ERF8 series connector J2
- F. Test board pads (footprint effects) for the ERF8 connector
- G. 10 mils of 10.5 mil wide signal trace

The figure below shows the location of the measurement reference plane.

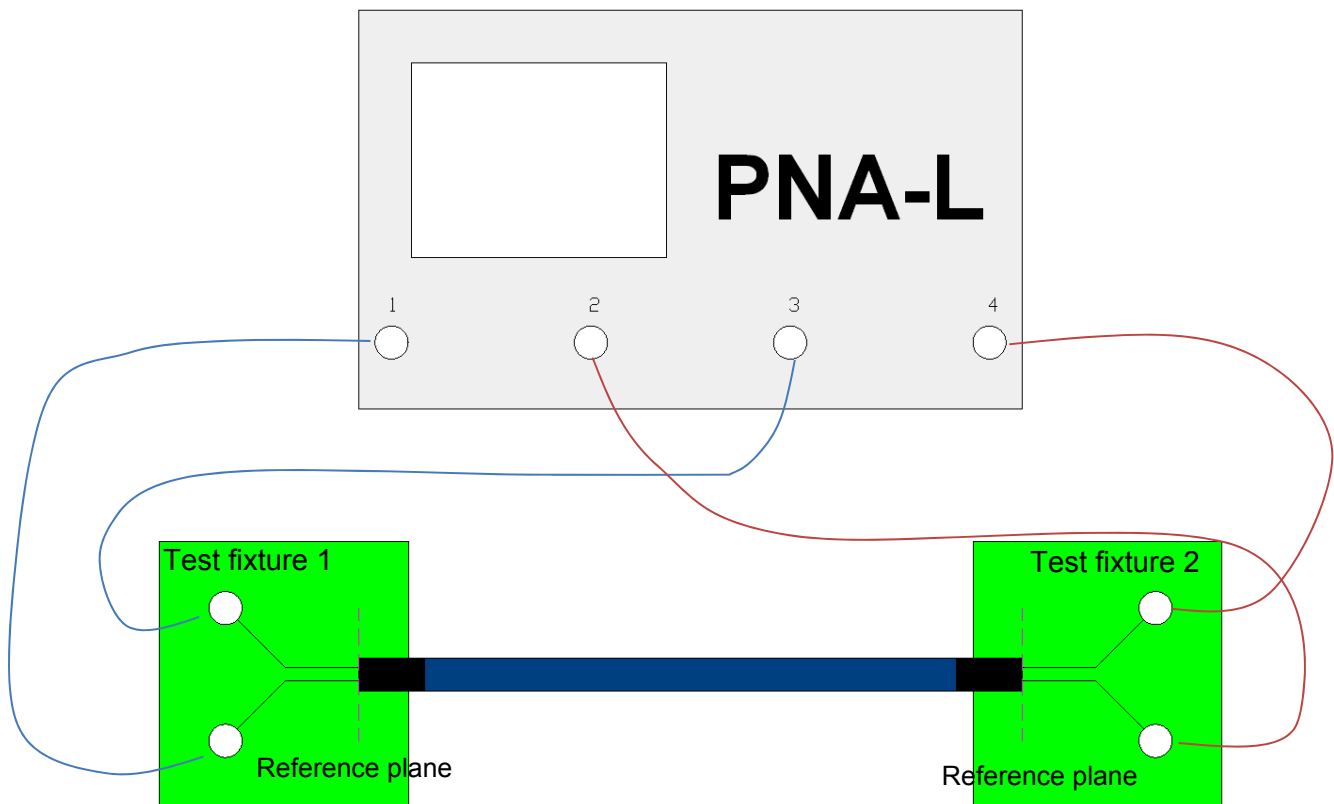

**Series:** (0.80 mm) .0315" ERCD

**Description:** 0.8mm Edge Rate High Speed Coax Cable Assembly

### **Time Domain Procedures**

Mathematically, Frequency Domain data can be transformed to obtain a Time Domain response. Perfect transformation requires Frequency Domain data from DC to infinity Hz. Fortunately, a very accurate Time Domain response can be obtained with bandwidth-limited data, such as measured with modern network analyzer.

The Time Domain responses were generated using Agilent ADS 2011 update 10. This tool has a transient convolution simulator, which can generate a Time Domain response directly from measured S-Parameters. An example of a similar methodology is provided in the Samtec Technical Note on domain transformation.

[http://www.samtec.com/Documents/WebFiles/Technical\\_Library/Reference/Articles/tech-note\\_using-PLTS-for-time-domain-data\\_web.pdf](http://www.samtec.com/Documents/WebFiles/Technical_Library/Reference/Articles/tech-note_using-PLTS-for-time-domain-data_web.pdf)

### Impedance (TDR)

Measurements involving digital pulses are performed using either Time Domain Reflectometer (TDR) or Time Domain Transmission (TDT) methods. The TDR method is used for the impedance measurements in this report.

The signal line(s) of the SUT's is energized with a TDR pulse and the far-end of the energized signal line is terminated in the test systems characteristic impedance (e.g.; 50Ω or 100Ω terminations). By terminating the adjacent signal lines in the test systems characteristic impedance, the effects on the resultant impedance shape of the waveform is limited. The "best case" signal mapping was tested and is presented in this report.

### Propagation Delay (TDT)

The Propagation Delay is a measure of the Time Domain delay through the cable assembly and footprint. A step pulse is applied to the touchstone model of the cable assembly and the transmitted voltage is monitored. The same pulse is also applied to a reference channel with zero loss, and the Time Domain pulses are plotted on the same graph. The difference in time, measured at the 50% point of the step voltage is the propagation delay.

**Series:** (0.80 mm) .0315" ERCD

**Description:** 0.8mm Edge Rate High Speed Coax Cable Assembly

## Appendix G – Glossary of Terms

ADS – Agilent Advanced Design System

AFR – Automatic Fixture Removal

CTLE – Continuous Time Linear Analyzer

DUT – Device under test

FD – Frequency domain

FEXT – Far-End Crosstalk

HDV – High Density Vertical

NEXT – Near-End Crosstalk

OV – Optimal Vertical

OH – Optimal Horizontal

PCB – Printed Circuit Board

PLTS – Agilent Physical Layer Design System

PPO – Pin Population Option

SE – Single-Ended

SI – Signal Integrity

SUT – System Under Test

S – Static (independent of PCB ground)

SOLT – acronym used to define Short, Open, Load & Thru Calibration Standards

TD – Time Domain

TDA – Time Domain Analysis

TDR – Time Domain Reflectometry

TDT – Time Domain Transmission

UI – Unit Interval

XROW – Across Row

Z – Impedance (expressed in ohms)